

Towbar

6065

Audi; Skoda; Seat; VW

- A3 2012->
- A3 Limousine 2014->
- A3 Sportback 2012->
- A3 Cabrio 2014->
- A3 Cabrio S-line 2014->
- Octavia 2013->
- Octavia Combi 2013->
- Octavia RS 2013->
- Octavia RS Combi 2013->
- Leon 2013->
- Leon SC 2013->
- Leon FR 2013->
- Leon SC FR 2013->
- Leon SC FR Edition 2013->
- Leon ST 2013->
- Leon ST FR 2013->
- Golf 2012->
- Golf GTI 2013->
- Golf Sportsvan 2014->



This Fitting Instruction is dated **19-012024**.

Always scan for the latest and most complete fitting instructions.



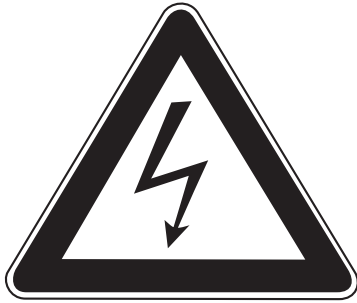

NL

- * Inbouwen in een high-voltage elektrische auto of in een hybride auto mag uitsluitend door gekwalificeerd personeel geschieden.
- * De voorgeschreven kwalificaties variëren naar gelang het gebied.
- * Neem de plaatselijk geldende wetgeving en de wettelijk voorgeschreven richtlijnen met betrekking tot service aan elektrische voertuigen in acht.
- * Het niet in acht nemen van deze instructie kan tot ernstig letsel en dood leiden.

GB

- * Fitting in a HV electric car or hybrid vehicle must only be done by qualified personnel.
- * The required qualifications may vary depending on the region.
- * Please observe the local legislation and legal directives relating to service to electric vehicles.

- * Disregarding these instructions may lead to serious injuries or death.

D

- * Der Einbau in ein HV Elektrofahrzeug/ Hybrid darf nur von qualifiziertem Personal durchgeführt werden.
- * Die erforderlichen Qualifikationen variieren je nach Region.
- * Beachten Sie die örtlichen Gesetze und gesetzlichen Richtlinien bezüglich Elektrofahrzeug-Service.
- * Das Missachten dieser Anweisung kann zu schweren Verletzungen oder zum Tod führen.

F

- * Le montage dans un véhicule électrique haute tension (HV) ou un véhicule hybride ne peut être fait que par du personnel qualifié.
- * Les qualifications requises sont variées selon la région.
- * Respectez les lois locales et les directives légales pour le service aux véhicules électriques.
- * Le non-respect de ces instructions peut provoquer des blessures graves ou entraîner la mort.

S

- * Monteringen i ett HS-elfordon eller ett hybridfordon få endast genomföras av kvalificerad personal.
- * Vilken kvalifikation som krävs kan variera från region till region.

- * Beakta alla lagar och bestämmelser som gäller i respektive land samt alla lagliga direktiv som gäller för servicearbeten på elfordon.
- * Om detta inte beaktas finns risk för mycket allvarlig kroppsskada eller livsfara.

DK

- * Indbygningen i et HV elektrisk køretøj eller hybridkøretøj må kun gennemføres af kvalificeret personale.
- * De krævede kvalifikationer varierer afhængigt af regionen.
- * Læs og overhold de lokale love og de lovmæssige bestemmelser vedr. service af elektriske køretøjer.
- * En manglende overholdelse af denne instruktion kan føre til alvorlige kvæstelser, evt. med døden til følge.

E

- * La instalación en un vehículo híbrido o en un vehículo eléctrico de alto voltaje solo puede ser realizada por personal cualificado.
- * Las calificaciones varían según la región.
- * Tenga en cuenta las leyes locales y las pautas legales con respecto al servicio del vehículo eléctrico.
- * Si no se siguen estas instrucciones, se pueden producir lesiones graves o la muerte.

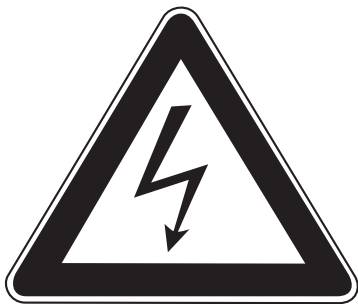

I

- * L'installazione in un'automobile ibrida oppure in un'automobile elettrica ad alta tensione (HV) può essere eseguita esclusivamente da parte di personale qualificato.
- * Le qualificazioni necessarie variano da regione a regione.
- * Tenere conto delle leggi e delle direttive valide a livello locale in relazione all'assistenza per le auto elettriche.
- * La mancata osservanza di queste istruzioni può causare lesioni gravi oppure la morte.

PL

- * Montaż w pojeździe z napędem elektrycznym HV lub z napędem hybrydowym może zostać wykonany wyłącznie przez wykwalifikowany personel.

* Wymagane kwalifikacje mogą różnić się zależnie od regionu, w którym dokonywany jest montaż.

* Wymagane jest przestrzeganie lokalnych przepisów prawnych i dyrektyw dotyczących serwisu pojazdów z napędem elektrycznym.

Nieprzestrzeganie powyższych wskazówek grozi ciężkimi urazami ciała lub utratą życia.

SF

* Asennuksen korkeajännitesähköajoneuvoon (HV) tai hybridiajoneuvoon saa suorittaa vain pätevä henkilöstö.

* Vaadittava pätevyys vaihtelee maakohtaisesti.

* Noudata sähköajoneuvon huoltoa koskevia paikallisia lakeja ja lain määräyksiä.

* Tämän ohjeen laiminlyönti voi aiheuttaa vakavan loukkaantumisen tai kuoleman.

CZ

* Vestavbu do elektrovozidla na vysoké napětí nebo do hybridního vozidla může provádět pouze kvalifikovaný personál.

* Dle daného státu se nezbytná požadovaná kvalifikace liší.

* Při servisních činnostech na elektrovozidlech postupujte dle místních zákonů a zákonných směrnic.

* Nedodržování těchto pokynů může mít za následek vážné úrazy a smrt.

H

* A beépítést egy nagyfeszültségű villamos gépjárműbe vagy egy hibrid gépjárműbe csak megfelelő képesítésű személyzet hajthatja végre.

* A szükséges képesítés régióról régióra változó. Kérjük, vegye tekintetbe a villamos gépjárművek szerivelésével kapcsolatos helyi törvényeket és törvényes irányelveket.

* Ezen Utasítás figyelmen kívül hagyása súlyos vagy halálos sérülésekhez vezethet.

RUS

* Монтаж в электромобиль HV или в гибридный автомобиль может производить только квалифицированный персонал.

* Уровень необходимой квалификации зависит от региональных требований.

* Обратите Ваше внимание на региональные законы и директивы согласно законодательству относительно сервиса для электромобилей.

* Несоблюдение данной инструкции может обусловить тяжелые травмы или привести к смертельному случаю.

1

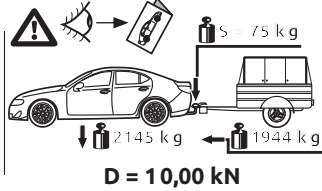
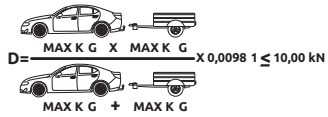

2

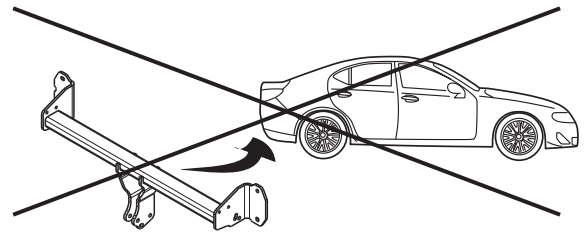
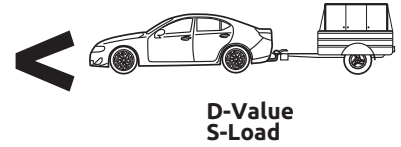
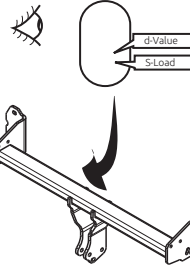

(B) Audi A3 Limouine S-line
 Audi A3 Sportback
 Audi A3 Cabrio S-line
 Škoda Octavia
 Škoda Octavia RS
 Škoda Octavia Combi
 Škoda Octavia Combi RS

(C) Audi A3
 Audi A3 Limouine
 Audi A3 Cabrio
 Seat Leon
 Seat Leon SC
 Seat Leon SC FR
 Seat Leon SC FR Edition
 Seat Leon ST

Seat Leon ST FR
 VW Golf
 VW Golf GTI
 VW Golf Sportsvan

ser.nr:

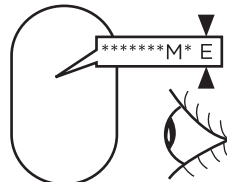

ser.nr:

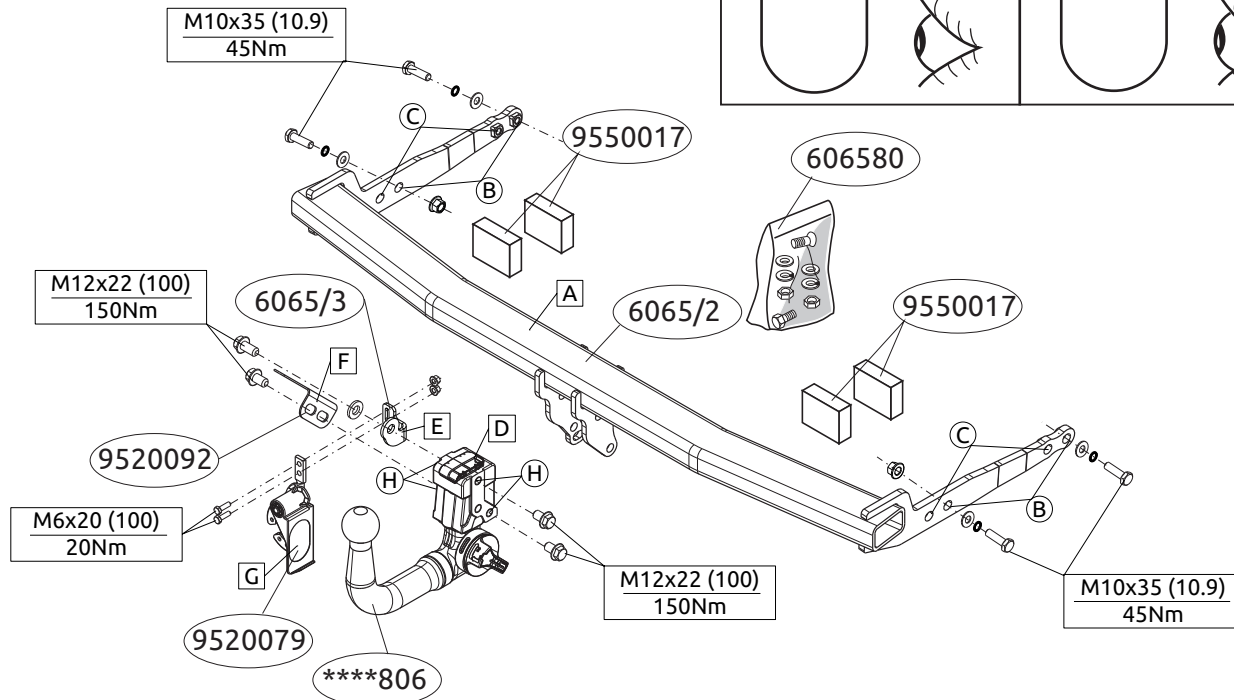
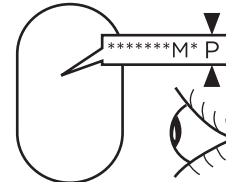

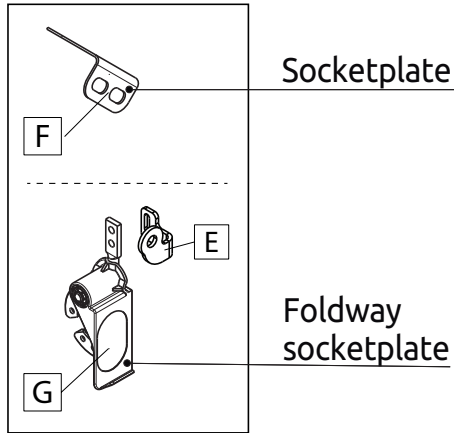

Audi A3 Sportback
Audi A3 Cabrio S-line
Audi A3
Audi A3 Limousine
Audi A3 Cabrio

G

Škoda Octavia
Škoda Octavia RS
Škoda Octavia Combi
Škoda Octavia Combi RS

G

Seat Leon
Seat Leon FR
Seat Leon SC
Seat Leon ST FR
Seat Leon SC FR Edition

F

Seat Leon ST

G

VW Golf
VW Golf GTI
VW Golf Sportsvan

G

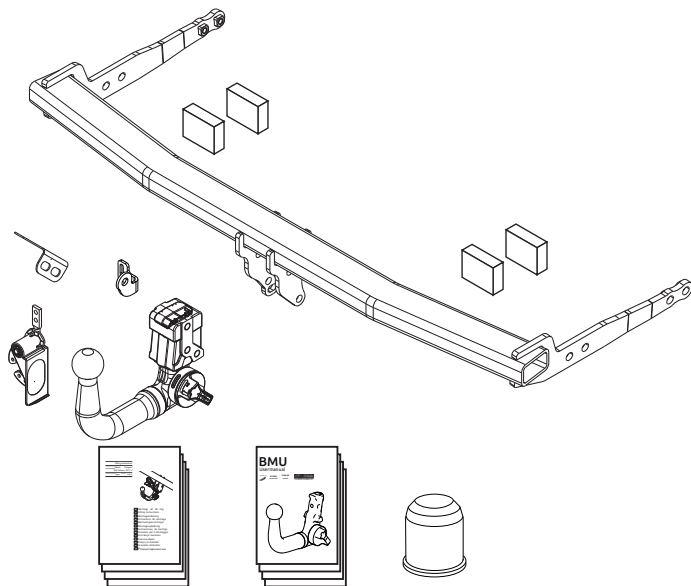
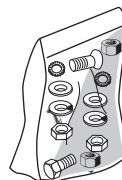
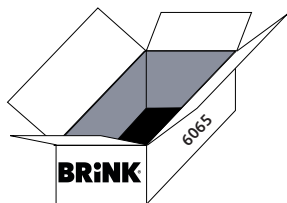

(4x) M12x25 (100)

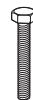

(4x) M10x35 (10.9)



(2x) M6x20 (10.9)



(2x) M6



(4x) M10



(4x) M10



(1x) M12

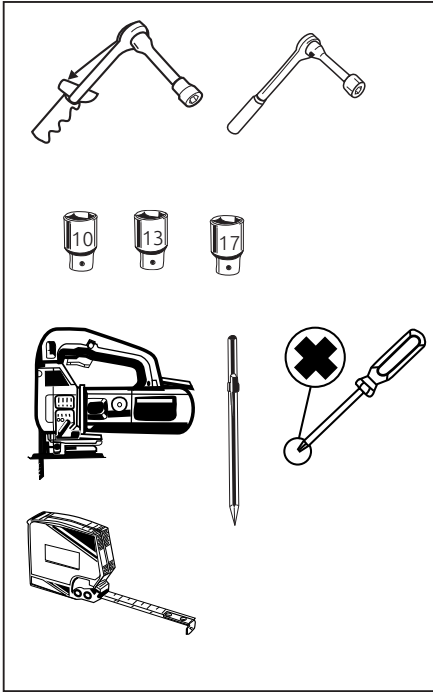

Couplingsclass: A50-X

euro tested

Approved

E11 55R 0110810

ECE R55

D-Value : 10,3 kN

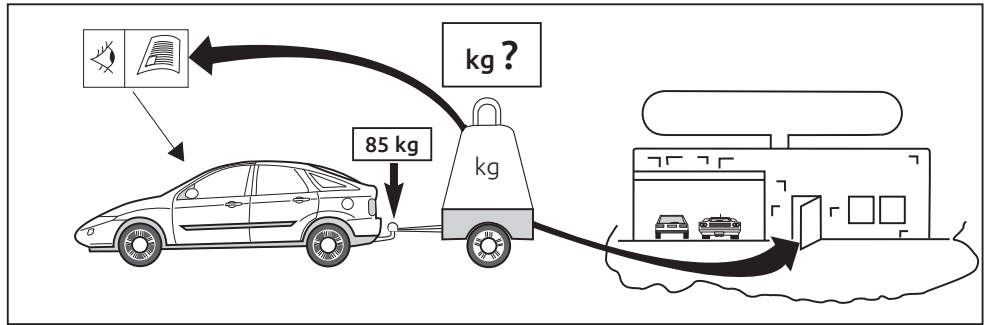

8.8

10.9

10

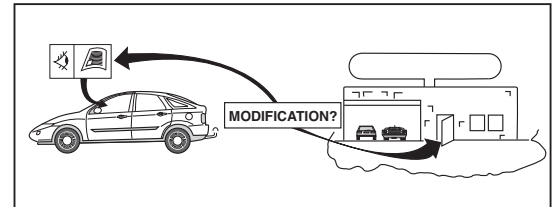

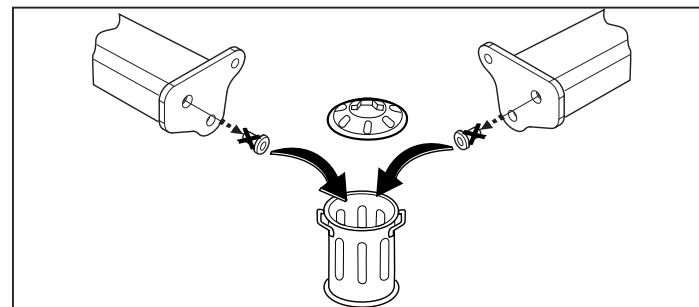
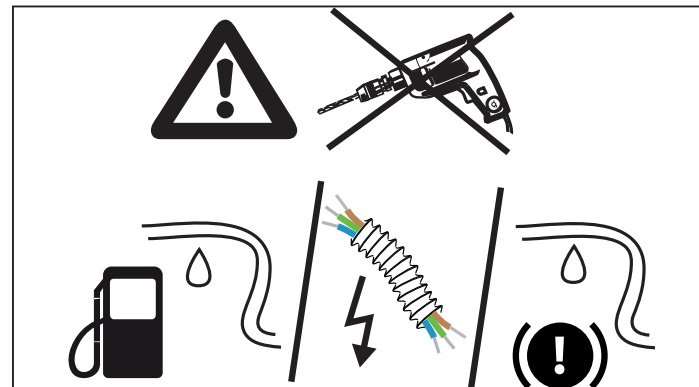
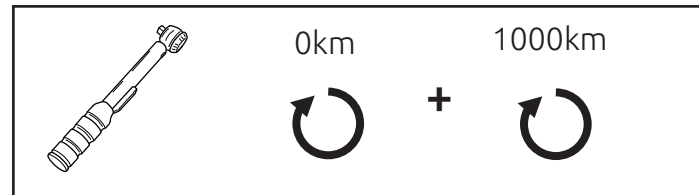
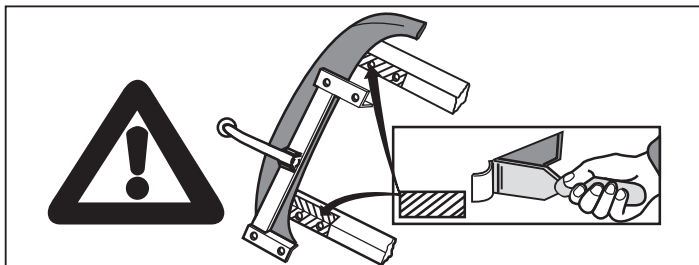
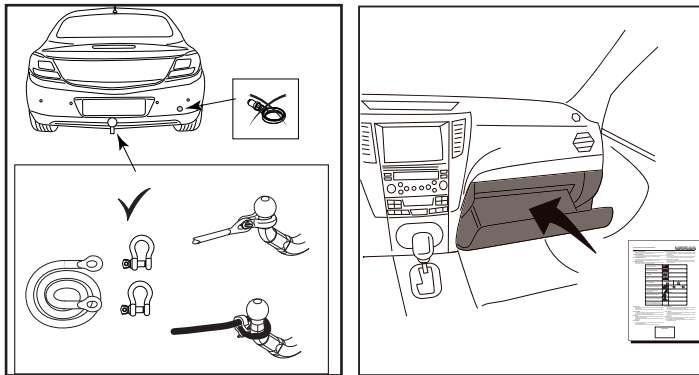
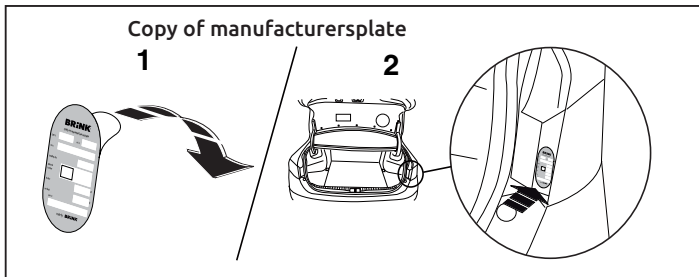

NL

* Brink Towing Systems B.V. is niet aansprakelijk voor de schade die het direct of indirect gevolg is van onjuiste montage, daaronder begrepen gebruik van niet-geschikte gereedschappen en het gebruik van andere dan de voorgeschreven montagewijze en middelen, dan wel onjuiste interpretatie van dit onderhavig montagevoorschrift.

GB

NOTE:

* **Should this installation process entail the cutting of the bumper – conformation MUST be obtained by the installation engineer of the customer's acceptance prior to completion. Brink Towing Systems B.V. do not accept responsibility for any matters arising as a result of this miscommunication.**

All measurements are in mm!

* Brink Towing Systems B.V. is not liable for damage caused directly or indirectly by incorrect assembly, including the use of unsuitable tools, the use of other assembly methods and means than the ones outlined, and the incorrect interpretation of these assembly instructions.

D

HINWEISE:

* Die für das Fahrzeug zugelassene Anhängelast ist den Fahrzeug Unterlagen zu entnehmen. Bei Änderungen des Fahrzeuggewichtes muß die höchstzulässige Anhängelast gegebenenfalls aus dem D-Wert nachgerechnet werden. Auskunft hierüber kann Ihr Fachhändler oder der TÜV geben.

* Elektrische Anlage gemäß StVZO anbringen.

* Brink Towing Systems B.V. haftet nicht für Schäden, die als direkte oder indirekte Folge einer nicht ordnungsgemäßen Montage auftreten, darunter fallen auch die Benutzung von ungeeigneten Werkzeugen, andere als die vorgeschriebenen Montageverfahren und Montagemittel

sowie eine fehlerhafte Interpretation der betreffenden Montageanweisung.

F

* Brink Towing Systems B.V. décline toute responsabilité pour les dommages qui pourraient directement ou indirectement résulter d'un montage incorrect, y compris l'utilisation d'outils inappropriés et l'utilisation d'un mode d'emploi et de moyens autres que ceux prescrits, ou bien résulter d'une interprétation inexacte des présentes instructions de montage.

S

* Brink Towing Systems B.V. är inte ansvariga för skada som orsakats direkt eller indirekt av felaktig montering, inklusive användning av olämpliga verktyg, andra monteringsmetoder och processer än de som beskrivs, samt felaktig tolkning av dessa monteringsinstruktioner.

DK

* Brink Towing Systems B.V. er ikke ansvarlig for skade der direkte eller indirekte er forårsaget af forkert montage, herunder også iberegnet brug af forkert værktøj og anvendelse af anden montage metode og andre montage midler end de foreskrevne samt fejltolkning af den medfølgende montagevejledning.

E

* Brink Towing Systems B.V. no se responsabiliza por daños causados, directa o indirectamente, por un montaje incorrecto, incluyendo el uso de herramientas inadecuadas, por el uso de métodos de montaje y medios distintos a los indicados y por la interpretación incorrecta de estas instrucciones de montaje.

I

* Brink Towing Systems B.V. non può essere ritenuta responsabile per eventuali danni direttamente o indirettamente dovuti ad un errato montaggio, intendendo con ciò anche l'uso di attrezzi non idonei e l'uso di metodi e mezzi di montaggio diversi da quelli prescritti, nonché all'errata interpretazione delle seguenti istruzioni di montaggio.

PL

* Brink Towing Systems B.V. nie ponosi odpowiedzialności za straty poniesione pośrednio lub bezpośrednio na skutek niewłaściwego montażu, w tym użycia niewłaściwych narzędzi i sposobów montażu niezgodnych z instrukcją, oraz niezastosowanie się do treści instrukcji.

SF

* Brink Towing Systems B.V. ei ole vastuussa vioittumisesta, joka on suoraaan tai epäsuoraaan aiheutunut väärästä asennuksesta samoin kuin sopimattomien työkalujen käytöstä, muiden kuin ohjeissa mainittujen asennusmenetelmien tai välineiden käytöstä sekä kyseisten asennusohjeiden väärintulkinnasta.

CZ

* Společnost Brink Towing Systems B.V. neodpovídá za přímé ani nepřímé škody způsobené nesprávnou montáží, včetně použití nevhodných nástrojů, použití jiných metod montáže a prostředků než uvedených a nesprávným pochopením těchto pokynů k montáži.

H

* A Brink Towing Systems B.V. nem vállal felelősséget a nem megfelelő szerelésből közvetlen vagy közvetett módon következő károkért. Ez vonatkozik a nem megfelelő szerszámok használatára, a leírtaktól eltérő módszerek és eszközök alkalmazására, valamint a szerelési útmutató

téves értelmezésére.

RUS

* Фирма Brink Towing Systems B.V. не отвечает за ущерб, являющийся прямым или косвенным следствием неправильного монтажа, в том числе использования неподходящих инструментов и применения иного способа монтажа или других средств, чем предписано в инструкции, либо неправильного истолкования настоящей инструкции по монтажу.

Audi

- NL** Lokatie/Positie pijl
- GB** Location/Position Arrow
- D** Positionspfeil
- F** Flèche de Position
- S** Positionpil
- DK** Lokaliseringspil
- E** Flecha de posición
- I** Freccia di posizione
- PL** Strzałka położenia
- SF** Paikannusnuoli
- CZ** Šípka na pozici
- H** Helyzetjelző nyíl
- RUS** Локация / Место

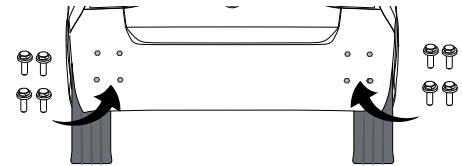
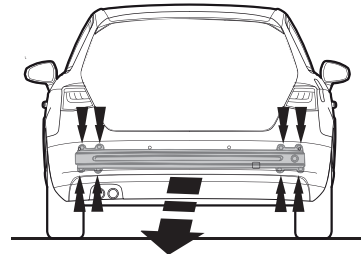
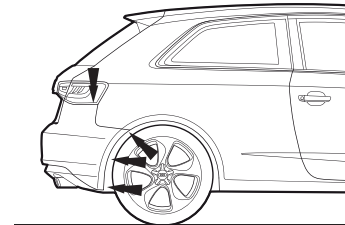
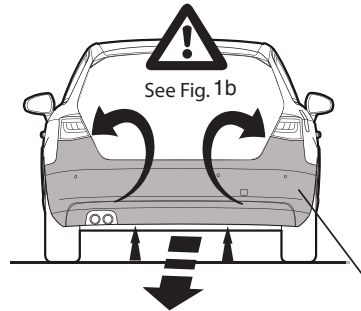
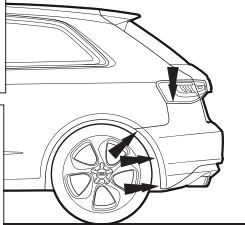
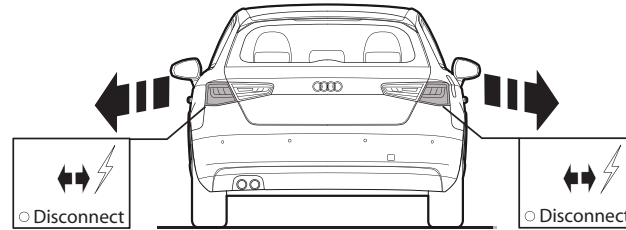

1a

- NL** Richtingspijl
- GB** Movement Arrow
- D** Bewegungspfeil
- F** Flèche de mouvement
- S** Rörelsepil
- DK** Bevægelsespil
- E** Flecha de movimiento
- I** Freccia di movimento
- PL** Strzałka kierunku ruchu
- SF** Liikesuuntanuoli
- CZ** Šípka pohybu
- H** Mozgásirányjelzőnyíl
- RUS** Стрелка движения

1

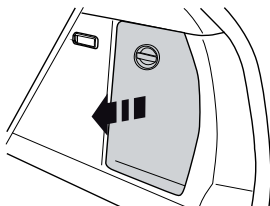
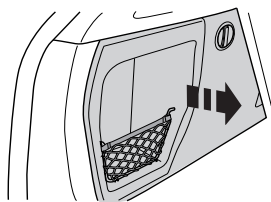

2

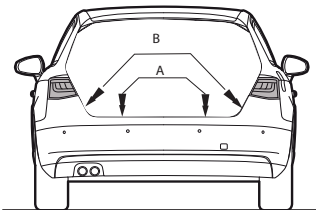
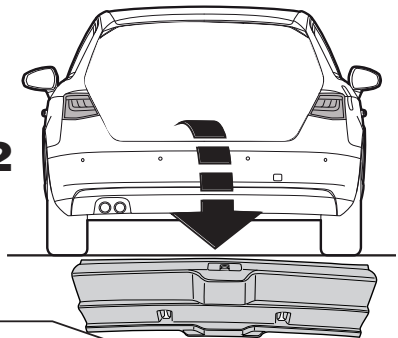

Audi

3

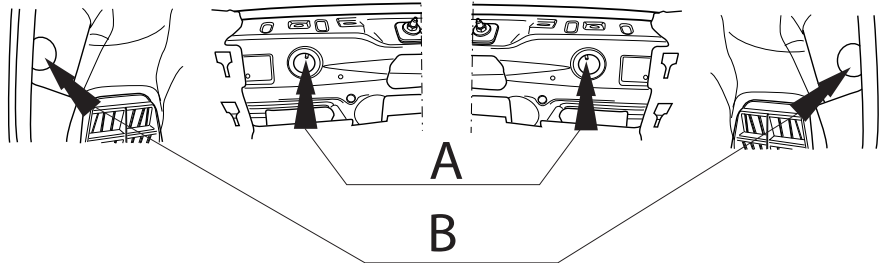

1b

Inside trunk / back panel

Skoda

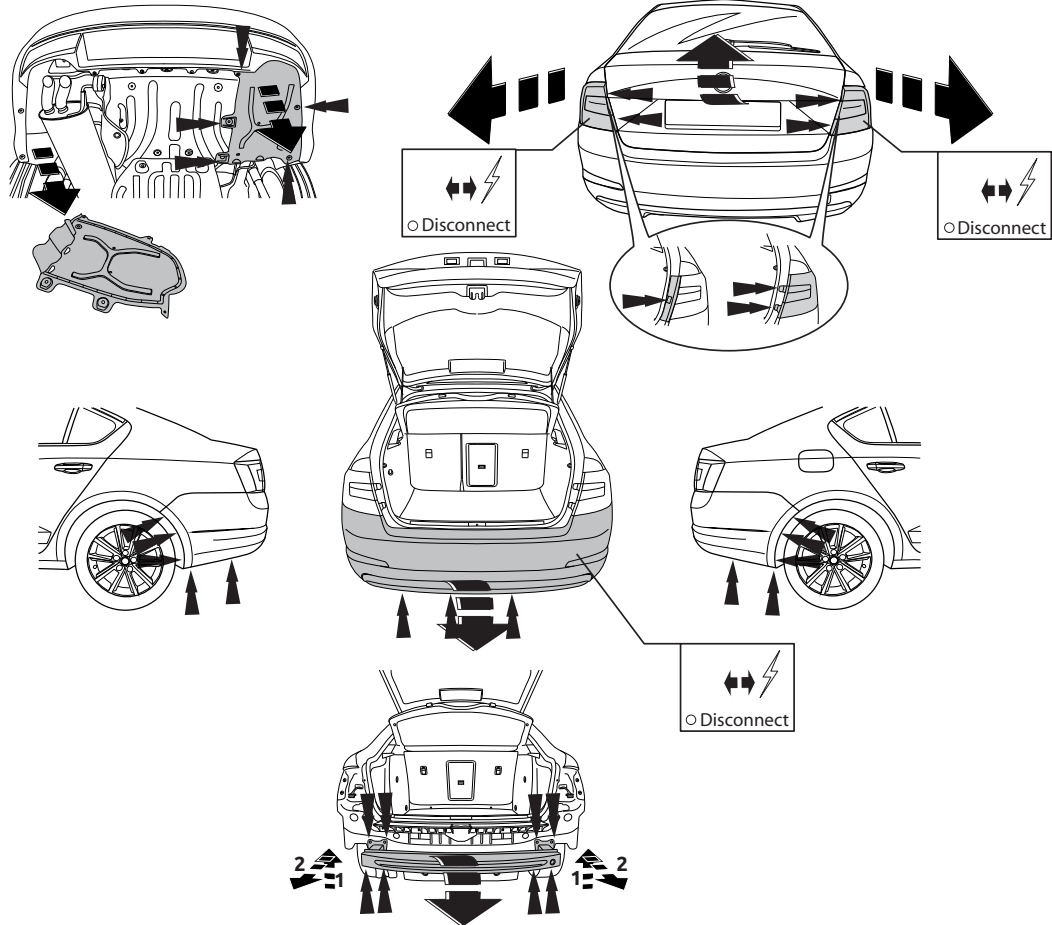

1c

Seat

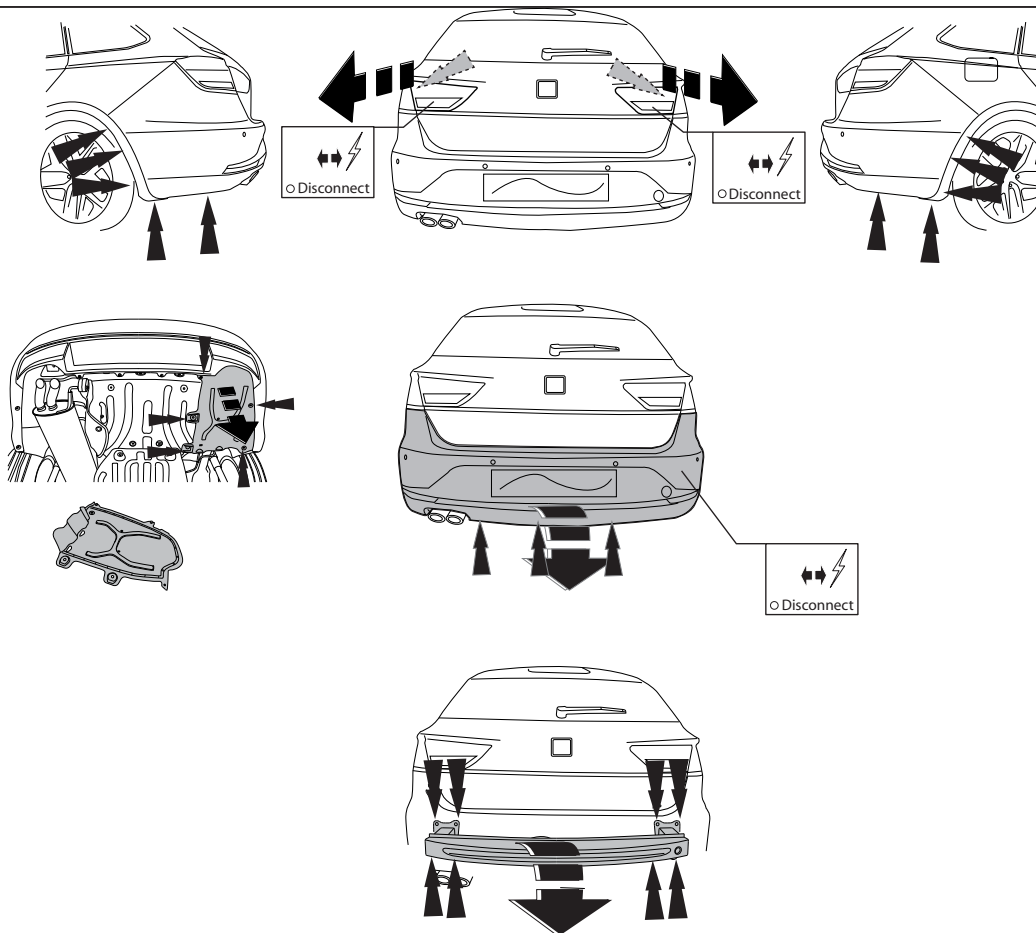

1d

Volkswagen

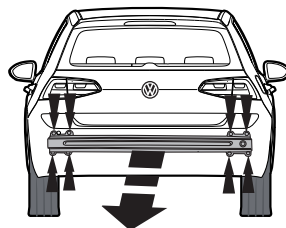
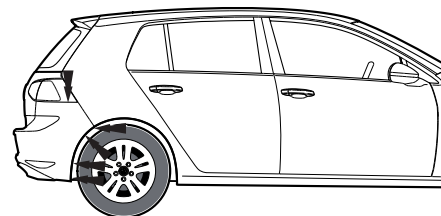
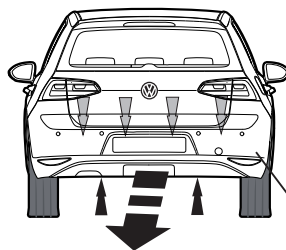
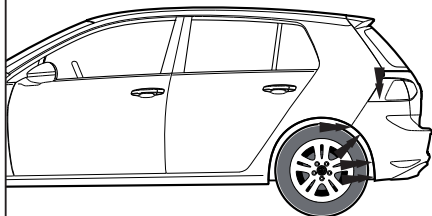
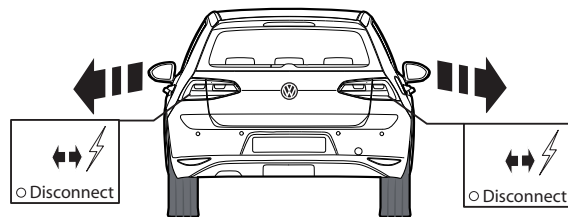

1e

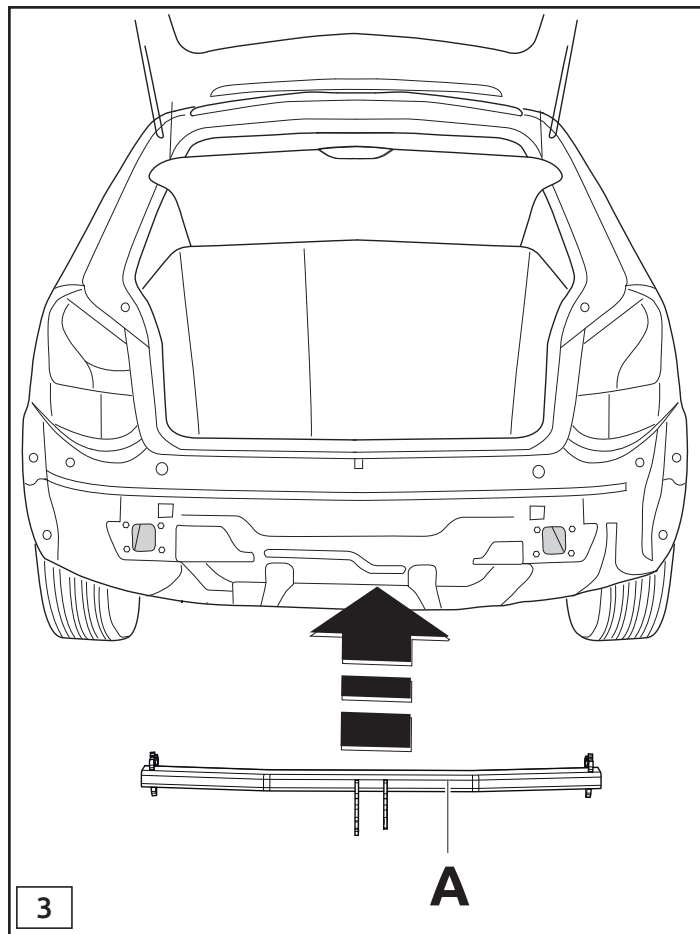
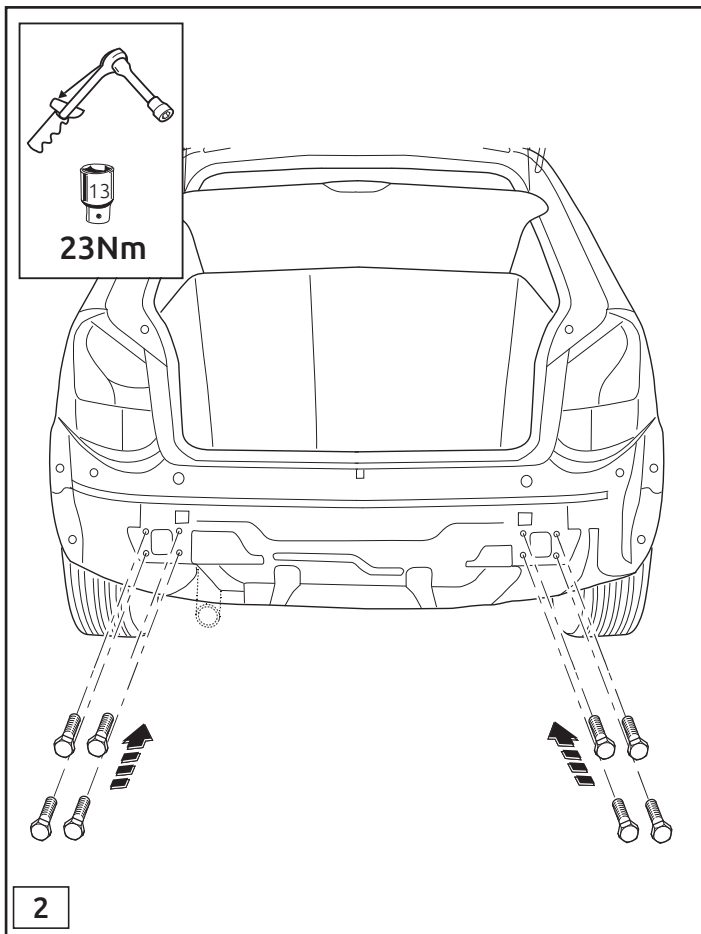

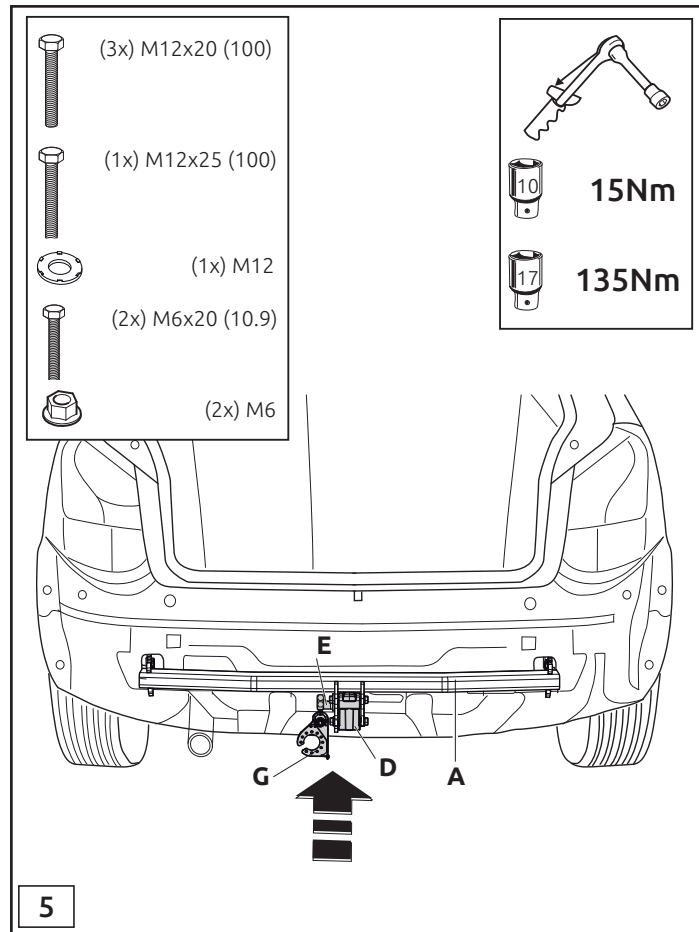
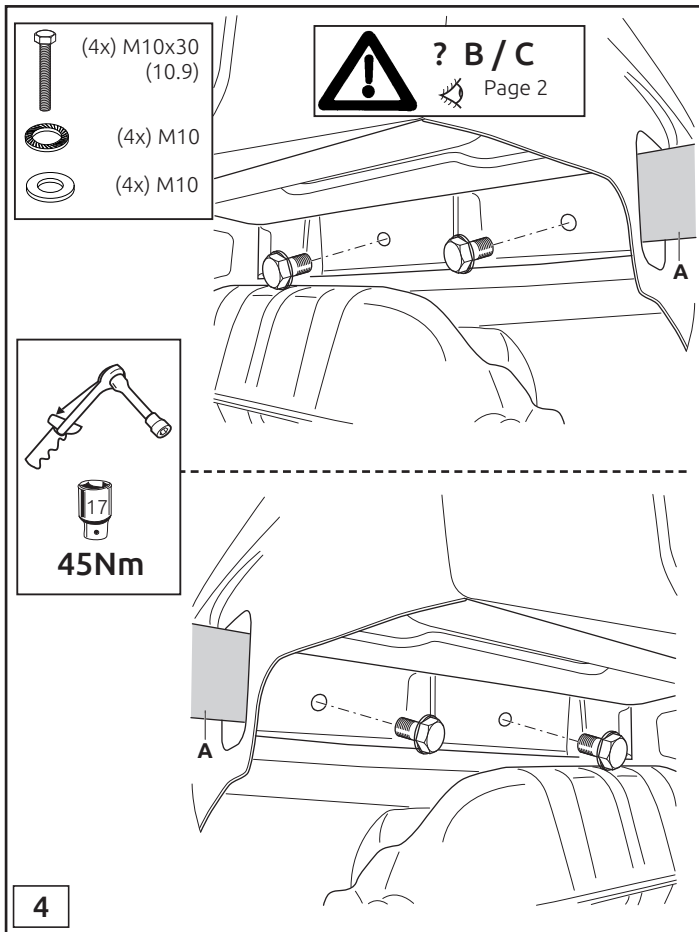

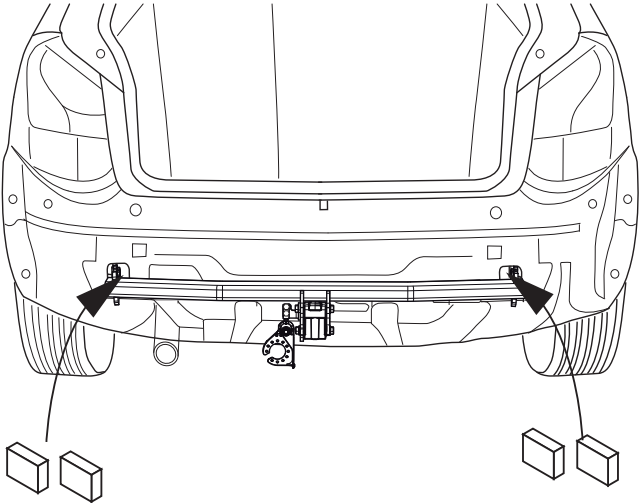

6



 Foldway socketplate

Audi A3
Audi A3 Sportback

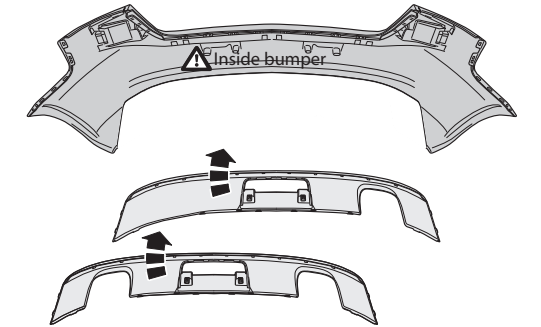
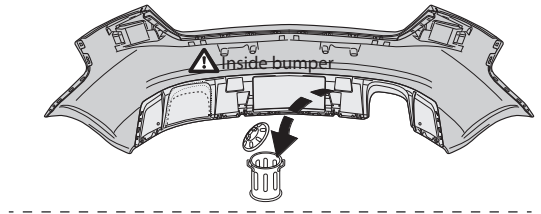
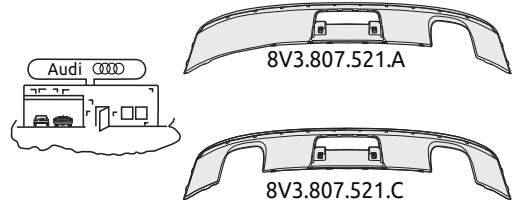

7



Foldway socketplate

Audi A3 Limousine

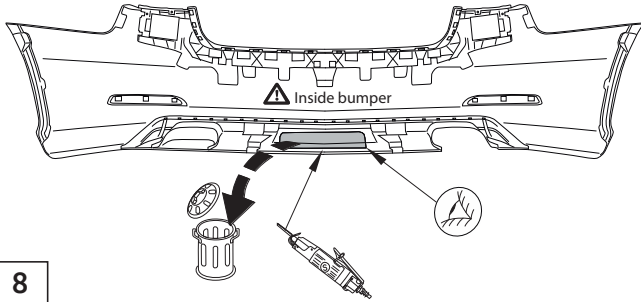

8



Foldway socketplate

Audi A3 Limousine

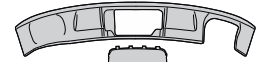
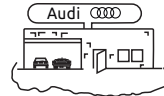

8V3.807.521.A

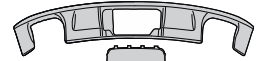

8V3.807.521.C

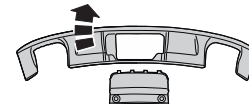
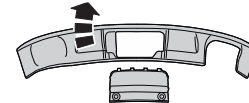
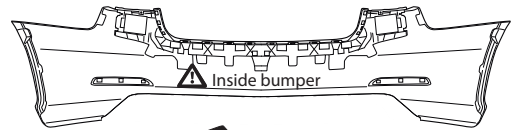
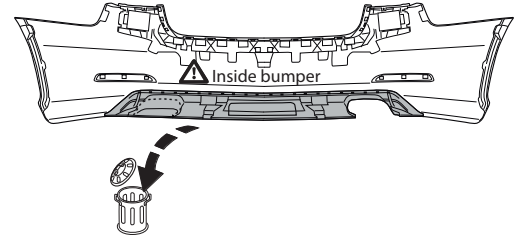

8a

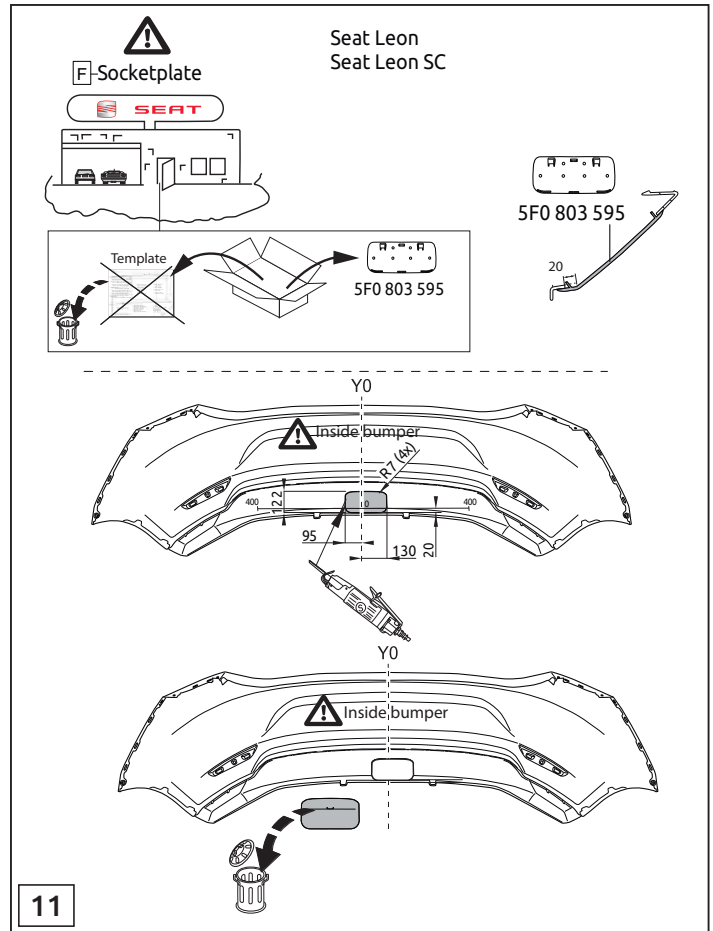
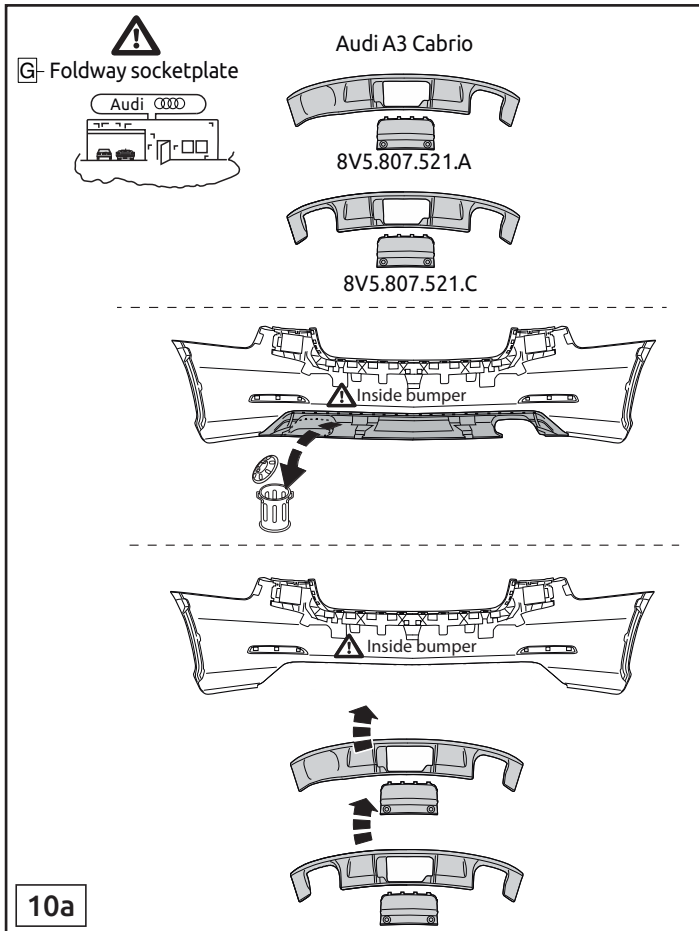

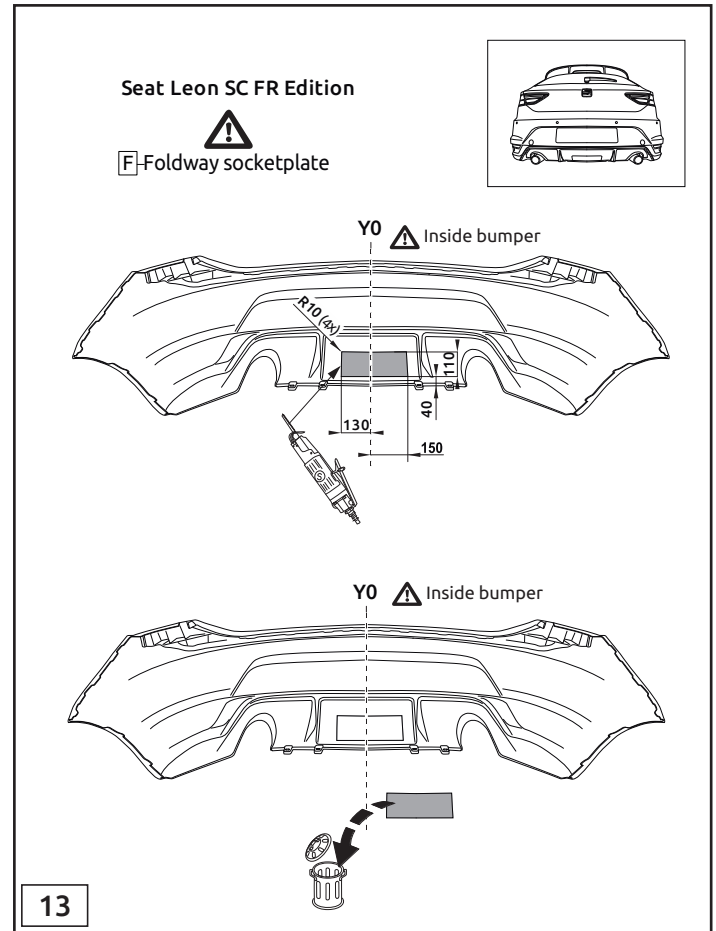
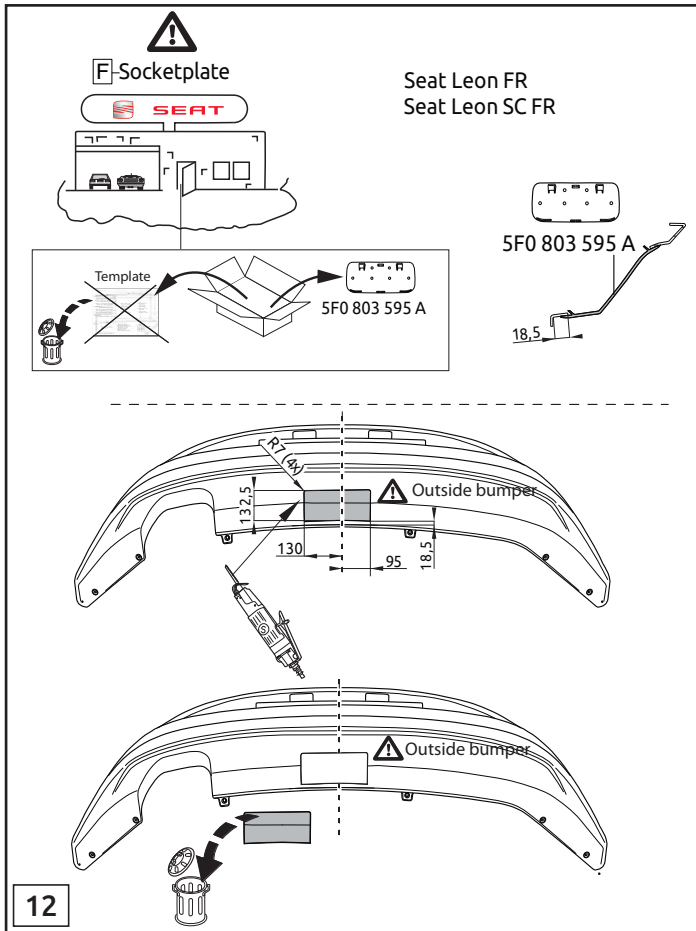

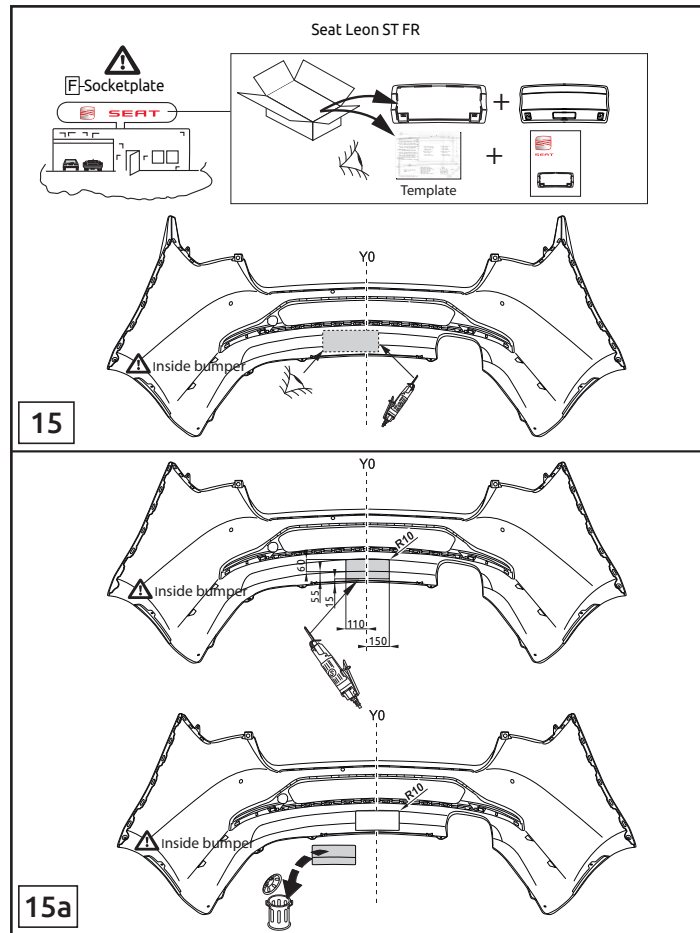
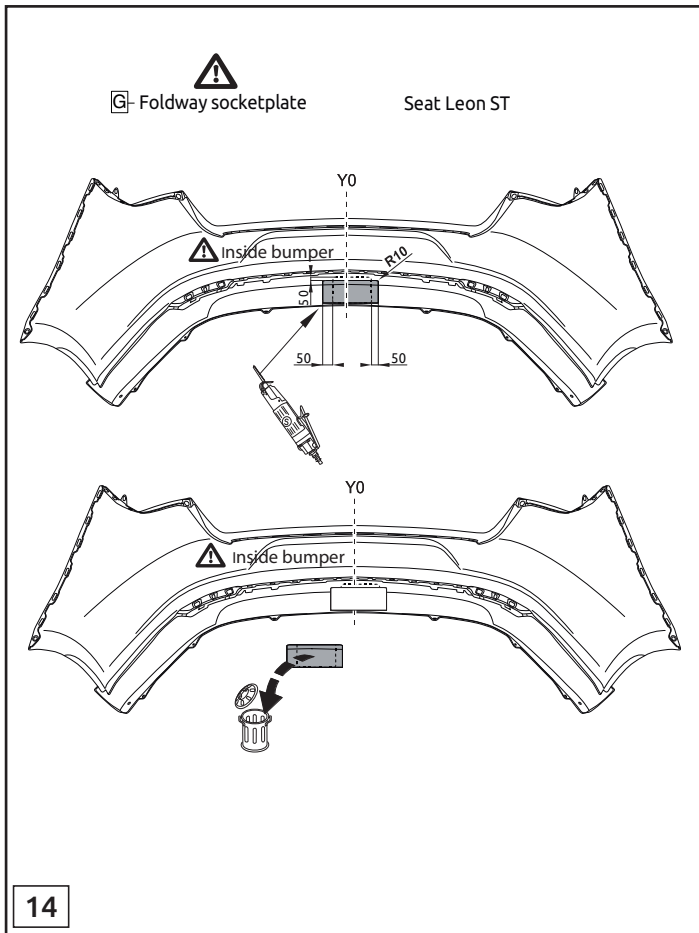

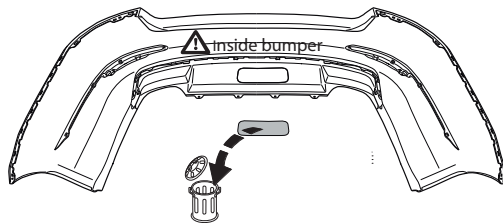
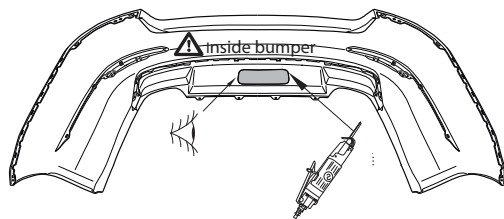

Škoda Octavia
Škoda Octavia Combi
Škoda Octavia RS
Škoda Octavia Combi RS

 Foldway socketplate



16

 Foldway socketplate

VW Golf

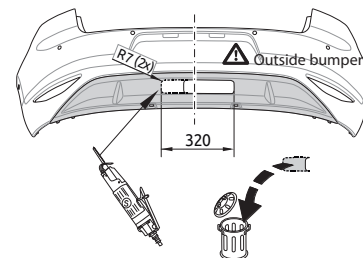
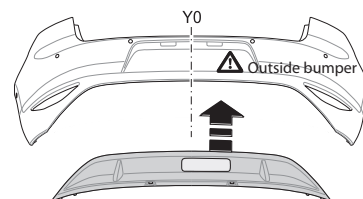
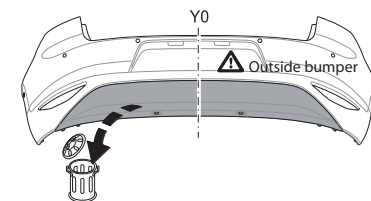
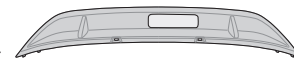

17

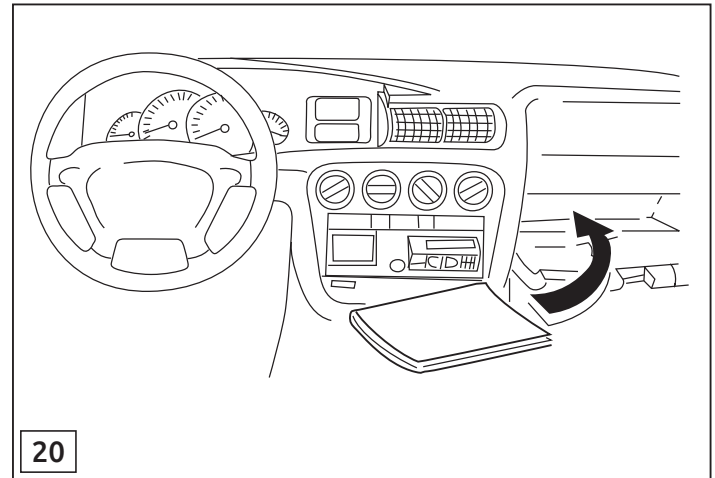
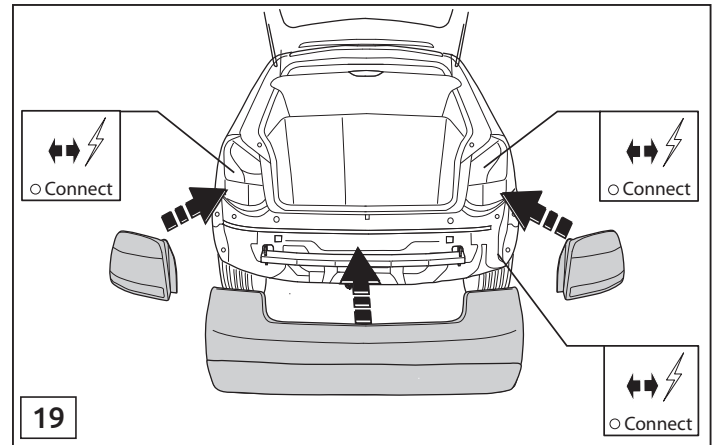
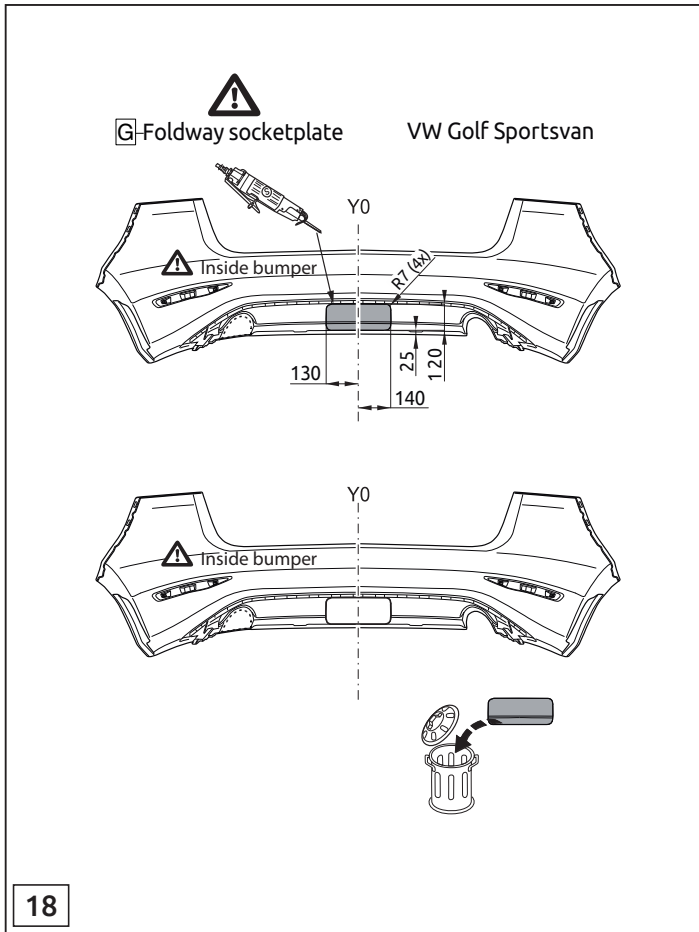



Dispositivo di traino tipo: 6065
Per autoveicoli: Audi **A3** 2012->; **A3 Limousine** 2014->; **A3 Sportback** 2012->; **A3 Cabrio** 2014->; **A3 Cabrio S-line** 2014->
Skoda **Octavia** 2013->; **Octavia Combi** 2013->; **Octavia RS** 2013->; **Octavia RS Combi** 2013->
Seat **Leon** 2013->; **Leon SC** 2013->; **Leon FR** 2013->; **Leon SC FR** 2013->; **Leon SC FR Edition** 2013->; **Leon ST** 2013->;
Leon ST FR 2013->
Volkswagen **Golf** 2012->; **Golf GTI** 2013->; **Golf Sportsvan** 2014->
Tipo funzionale: 5G, 8V, 5E, AU, 5F, NX5
Classe e tipo di attacco: A50-X
Omologazione: E11 55R 0110810
Valore D: 10,3 kN
Carico Verticale max. S: 85 kg
Larghezza rimorchiabile per Caravan e T.A.T.S.: 2,45m vedere CARTA di CIRCOLAZIONE VEICOLO (motrice) + 70 cm = ..arrotondare ai 5 cm superiore (vedi D.M.28/05/85)
Massa rimorchiabile: vedi carta di circolazione dell' autoveicolo

Per verificare l'idoneità del dispositivo di traino omologato a norma UN ECE R55, all'installazione sulla vettura su cui si intende procedere al montaggio, compilare la seguente formula (se necessario declassare la massa rimorchiabile):

$$D = \frac{T \times C}{T + C} \times 0,00981 \leq 10,3 \text{ kN}$$

dove: T= Massa Complessiva Max. della motrice (in kg)

C= Massa Rimorchiabile Max. della motrice (in kg)

DA COMPILARE PER IL COLLAUDO

DICHIARAZIONE DI CORRETTO MONTAGGIO: la sottoscritta Ditta dichiara di aver montato in maniera corretta ed in conformità/alle prescrizioni sia del costruttore del veicolo che del costruttore del dispositivo stesso il seguente dispositivo di attacco meccanico:

tipo:.....

Il dispositivo di attacco sopra indicato è stato installato su autoveicolo

modello:.....

targa:.....

Data:.....

TIMBRO e FIRMA

Si dichiara inoltre di aver informato l'utente del veicolo sull'USO e MANUTENZIONE del dispositivo stesso.

Towbar

6065

Audi; Skoda; Seat; VW

• A3	2012->	• Leon SC FR	2013->
• A3 Limousine	2014->	• Leon SC FR Edition	2013->
• A3 Sportback	2012->	• Leon ST	2013->
• A3 Cabrio	2014->	• Leon ST FR	2013->
• A3 Cabrio S-line	2014->	• Golf	2012->
• Octavia	2013->	• Golf GTI	2013->
• Octavia Combi	2013->	• Golf Sportsvan	2014->
• Octavia RS	2013->		
• Octavia RS Combi	2013->		
• Leon	2013->		
• Leon SC	2013->		
• Leon FR	2013->		

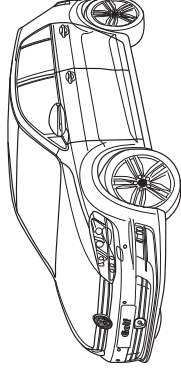
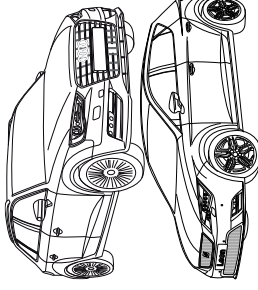

This Fitting Instruction is dated **19-012024**. Always scan for the latest and most complete fitting instructions.



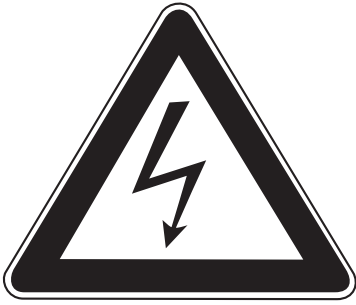

NL

- * Inbouwen in een high-voltage elektrische auto of in een hybride auto mag uitsluitend door gekwalificeerd personeel geschieden.
- * De voorgeschreven kwalificaties variëren naar gelang het gebied.
- * Neem de plaatselijk geldende wetgeving en de wettelijk voorgeschreven richtlijnen met betrekking tot service aan elektrische voertuigen in acht.
- * Het niet in acht nemen van deze instructie kan tot ernstig letsel en dood leiden.

GB

- * Fitting in a HV electric car or hybrid vehicle must only be done by qualified personnel.
- * The required qualifications may vary depending on the region.
- * Please observe the local legislation and legal directives relating to service to electric vehicles.

* Disregarding these instructions may lead to serious injuries or death.

D

- * Der Einbau in ein HV Elektrofahrzeug/ Hybrid darf nur von qualifiziertem Personal durchgeführt werden.
- * Die erforderlichen Qualifikationen variieren je nach Region.
- * Beachten Sie die örtlichen Gesetze und gesetzlichen Richtlinien bezüglich Elektrofahrzeug-Service.
- * Das Missachten dieser Anweisung kann zu schweren Verletzungen oder zum Tod führen.

F

- * Le montage dans un véhicule électrique haute tension (HV) ou un véhicule hybride ne peut être fait que par du personnel qualifié.
- * Les qualifications requises sont variées selon la région.
- * Respectez les lois locales et les directives légales pour le service aux véhicules électriques.
- * Le non-respect de ces instructions peut provoquer des blessures graves ou entraîner la mort.

S

- * Monteringen i ett HS-elfordon eller ett hybridfordon få endast genomföras av kvalificerad personal.
- * Vilken kvalifikation som krävs kan variera från region till region.

* Beakta alla lagar och bestämmelser som gäller i respektive land samt alla lagliga direktiv som gäller för servicearbeten på elfordon.

* Om detta inte beaktas finns risk för mycket allvarlig kroppsskada eller livsfara.

DK

- * Indbygningen i et HV elektrisk køretøj eller hybridkøretøj må kun gennemføres af kvalificeret personale.
- * De krævede kvalifikationer varierer afhængigt af regionen.
- * Læs og overhold de lokale love og de lovmæssige bestemmelser vedr. service af elektriske køretøjer.
- * En manglende overholdelse af denne instruktion kan føre til alvorlige kvæstelser, evt. med døden til følge.

E

- * La instalación en un vehículo híbrido o en un vehículo eléctrico de alto voltaje solo puede ser realizada por personal cualificado.
- * Las calificaciones varían según la región.
- * Tenga en cuenta las leyes locales y las pautas legales con respecto al servicio del vehículo eléctrico.
- * Si no se siguen estas instrucciones, se pueden producir lesiones graves o la muerte.

© 606570/19-01-2024/2



Dispositivo di traino tipo: 6065
 Per autoveicoli: Audi **A3** 2012->; **A3 Limousine** 2014->; **A3 Sportback** 2012->; **A3 Cabrio** 2014->; **A3 Cabrio S-line** 2014->
 Skoda **Octavia** 2013->; **Octavia Combi** 2013->; **Octavia RS** 2013->; **Octavia RS Combi** 2013->
 Seat **Leon** 2013->; **Leon SC** 2013->; **Leon FR** 2013->; **Leon SC FR** 2013->; **Leon SC FR Edition** 2013->; **Leon ST** 2013->;
Leon ST FR 2013->
 Volkswagen **Golf** 2012->; **Golf GTI** 2013->; **Golf Sportsvan** 2014->
 Tipo funzionale: 5G, 8V, 5E, AU, 5F, NX5
 Classe e tipo di attacco: A50-X
 Omologazione: E11 55R 0110810
 Valore D: 10,3 kN
 Carico Verticale max. S: 85 kg
 Larghezza rimorchiabile per Caravan e T.A.T.S.: 2,45m vedere CARTA di CIRCOLAZIONE VEICOLO (motrice) + 70 cm = ..arrotondare ai 5 cm superiore (vedi D.M.28/05/85)
 Massa rimorchiabile: vedi carta di circolazione dell' autoveicolo

Per verificare l'idoneità del dispositivo di traino omologato a norma UN ECE R55, all'installazione sulla vettura su cui si intende procedere al montaggio, compilare la seguente formula (se necessario declassare la massa rimorchiabile):

$$D = \frac{T \times C}{T + C} \times 0,00981 \leq 10,3 \text{ kN}$$

dove: T= Massa Complessiva Max. della motrice (in kg)
C= Massa Rimorchiabile Max. della motrice (in kg)

DA COMPILARE PER IL COLLAUDO

DICHIARAZIONE DI CORRETTO MONTAGGIO: la sottoscritta Ditta dichiara di aver montato in maniera corretta ed in conformità/alle prescrizioni sia del costruttore del veicolo che del costruttore del dispositivo stesso il seguente dispositivo di attacco meccanico:

tipo:.....
 Il dispositivo di attacco sopra indicato è stato installato su autoveicolo
 modello:.....
 targa:.....
 Data:.....

TIMBRO e FIRMA

Si dichiara inoltre di aver informato l'utente del veicolo sull'USO e MANUTENZIONE del dispositivo stesso.

© 606570/19-01-2024/27

H

- * A beépítést egy nagyfeszültségű villamos gépjárműbe vagy egy hibrid gépjárműbe csak megfélelő képesítésű személyzet hajthatja végre.
- * A szűkséges képesítés régiórol régióra váltózó. Kérjük, vegye tekintetbe a villamos gépjárművek szerelésével kapcsolatos helyi követelményeket. Ezen Utasítás figyelemmel kivül hagyása súlyos vagy halálos sérüléssekhez vezethet.

RUS

- * Монтаж в электромобиль HV или в гибридном автомобиле может производиться только квалифицированным персоналом. Уровень необходимой квалификации зависит от региональных требований.
- * Обратите Ваше внимание на региональные законы и директивы согласно законодательства относительно сервиса для электро-мобилей.
- * Несоблюдение данной инструкции может обусловить тяжёлые травмы или привести к смертельному случаю.

I

- * L'installazione in un'automobile ibrida oppure (HV) può essere eseguita esclusivamente da parte di personale qualificato.
- * Le qualificazioni necessarie variano da regione a regione.
- * Tenere conto delle leggi e delle direttive valide a livello locale in relazione all'assistenza per le auto elettriche.
- * La mancata osservanza di queste istruzioni può causare lesioni gravi oppure la morte.

Z

- * Vestavbu do elektrovozidla na vysoké napětí nebo do hybridního vozidla může provádět pouze kvalifikovaný personál.
- * Die daného státu se nezbytná požadovaná kvalifikace liší.
- * Při servisních činnostech na elektrovozidlech postupujte dle místních zákonů a zákonných předpisů.
- * Nedodržování těchto pokynů může mít za následek vážné úrazy a smrt.

SF

- * Asennuksen korkeajännitesähköajoneuvoon (HV) tai hybridajoneuvoon saa suorittaa vain pätevä henkilöstö.
- * Vaadittava pätevyys vaihtelee maakohteisesti. Noudata sähköajoneuvon huolto-ohjeita paikallisissa lakeissa ja lain määräyksissä.
- * Tämä ohjeen laiminlyönti voi aiheuttaa vakavia loukkaantumisen tai kuoleman.

CZ

- * Wymagane jest przeszczenie lokalnych przepisów prawnych i dyrektyw dotyczących serwisowania pojazdów z napędem elektrycznym.
- * Nieprzeszczenie powyższych wskazówek grozi ciężkimi urazami ciała lub utratą życia.

PL

- * Montaż w pojeździe z napędem elektrycznym lub z napędem hybrydowym może zostać wykonany wyłącznie przez wykwalifikowany personel.

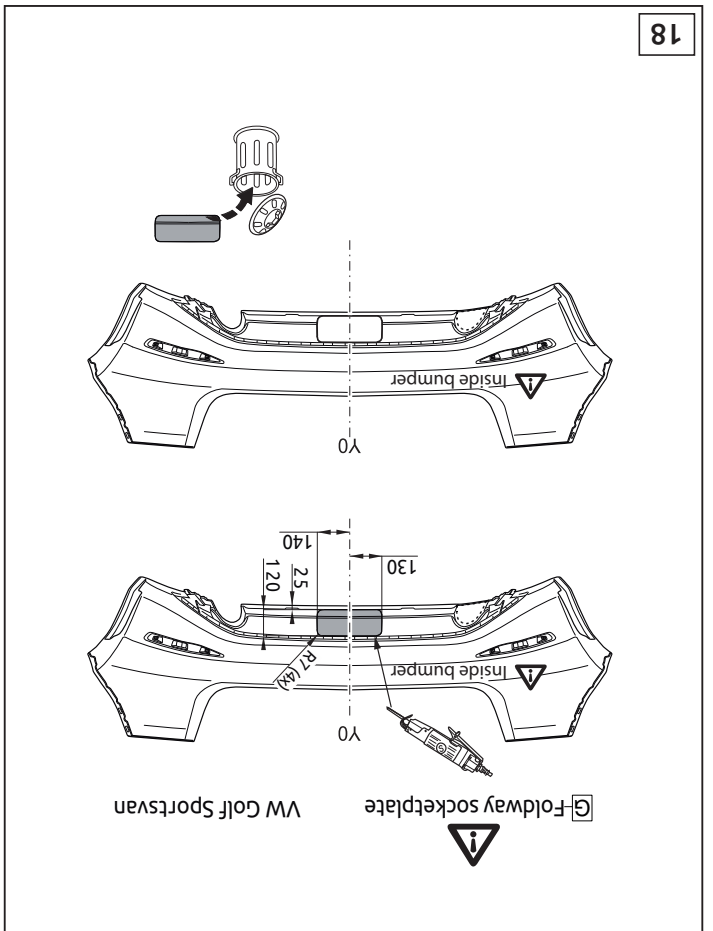
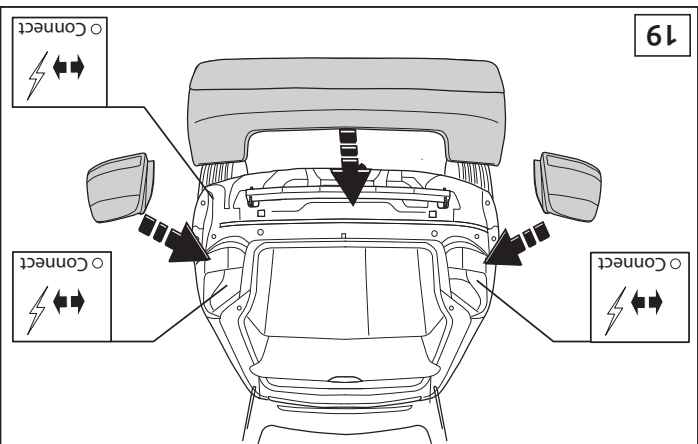
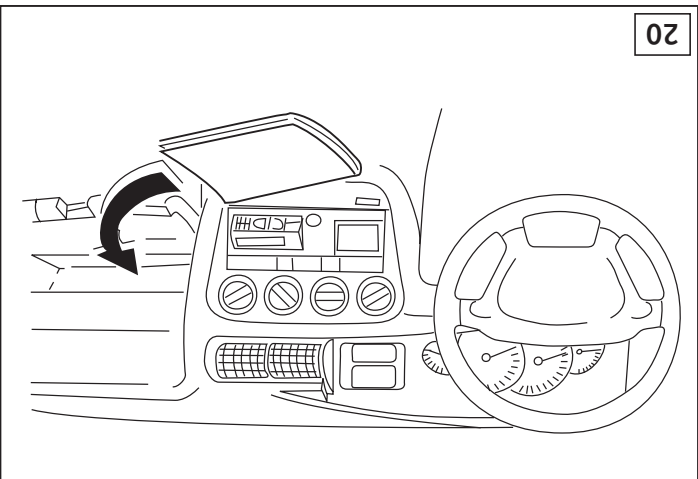
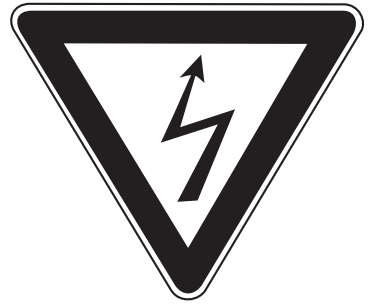

1



$$D = \frac{\text{MAX KG} \times \text{MAX KG}}{10,0098} \leq 10,00 \text{ kN}$$

$$\text{MAX KG} + \text{MAX KG}$$

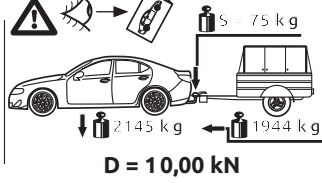

2

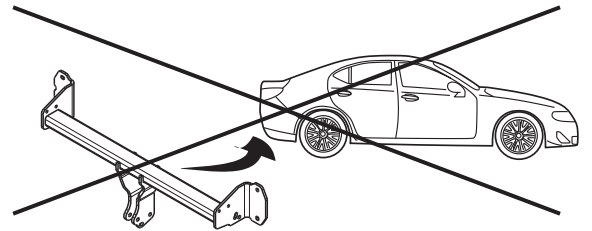
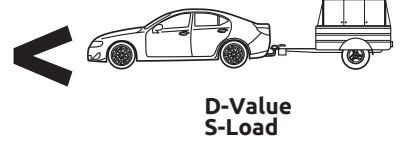
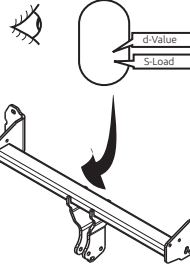

© 606570/19-01-2024/4

Škoda Octavia
 Škoda Octavia Combi
 Škoda Octavia RS
 Škoda Octavia Combi RS

Foldway socketplate

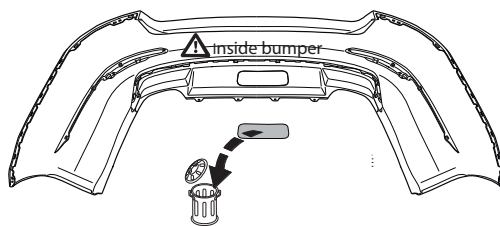
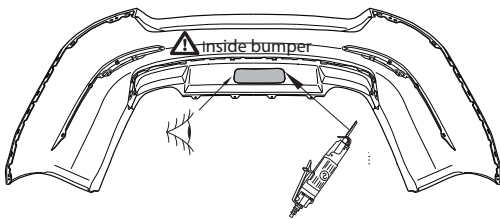

16

Foldway socketplate

VW Golf

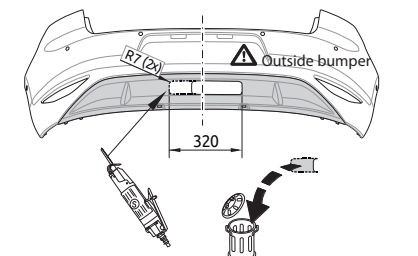
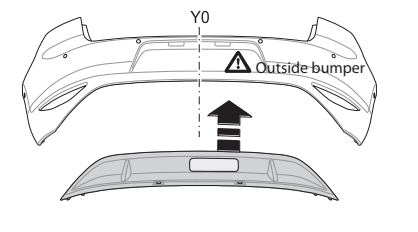
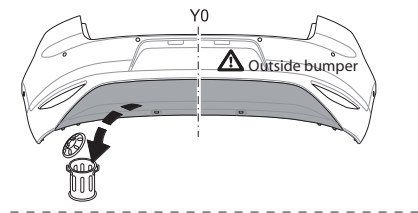
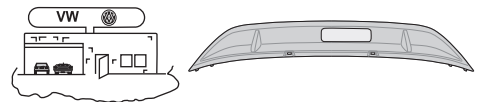

17

© 606570/19-01-2024/25

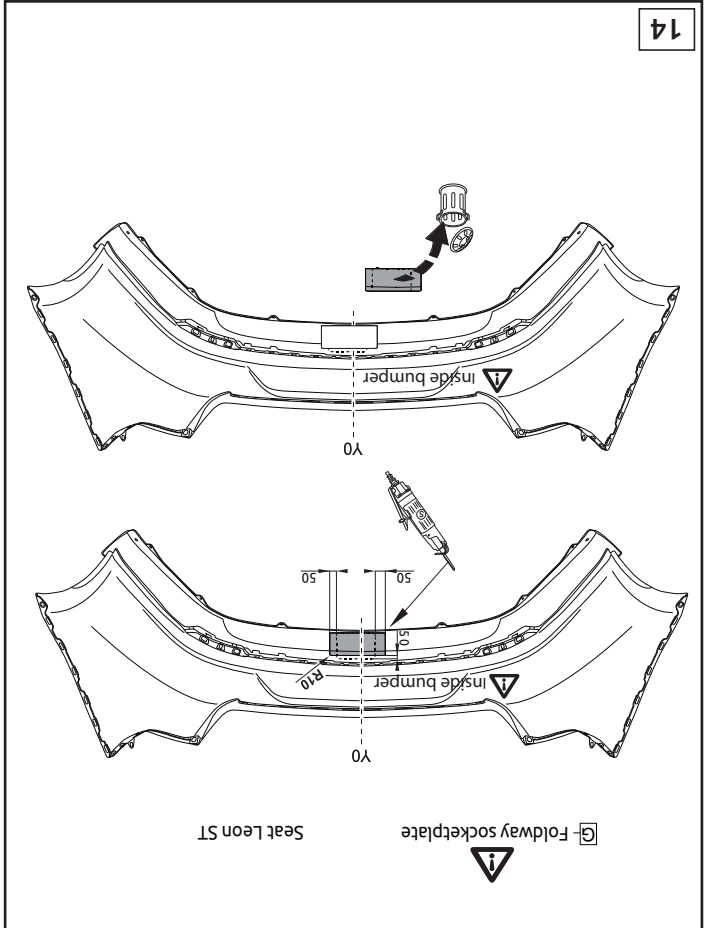
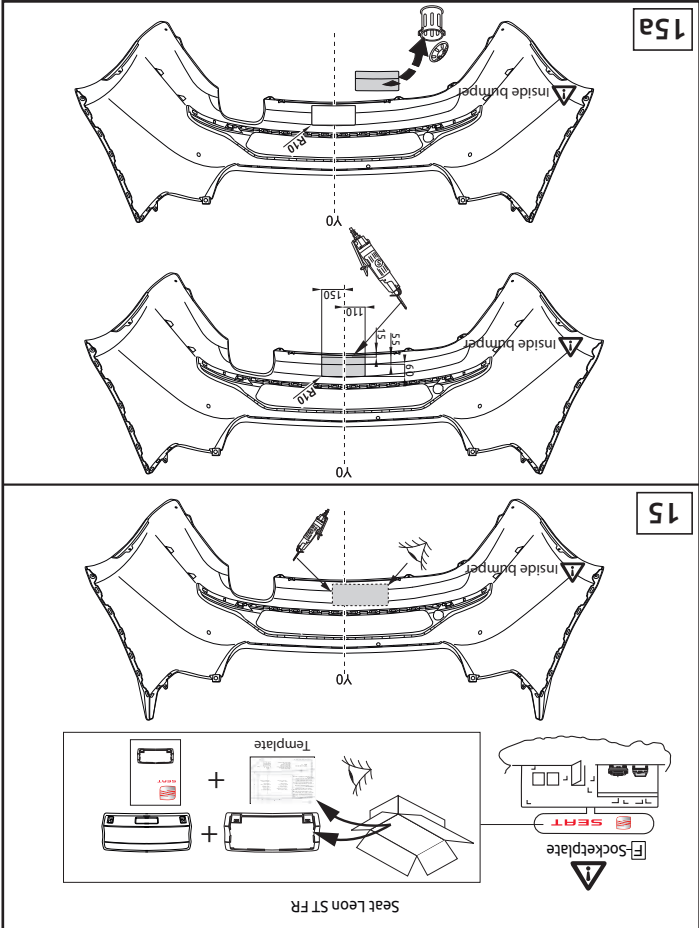
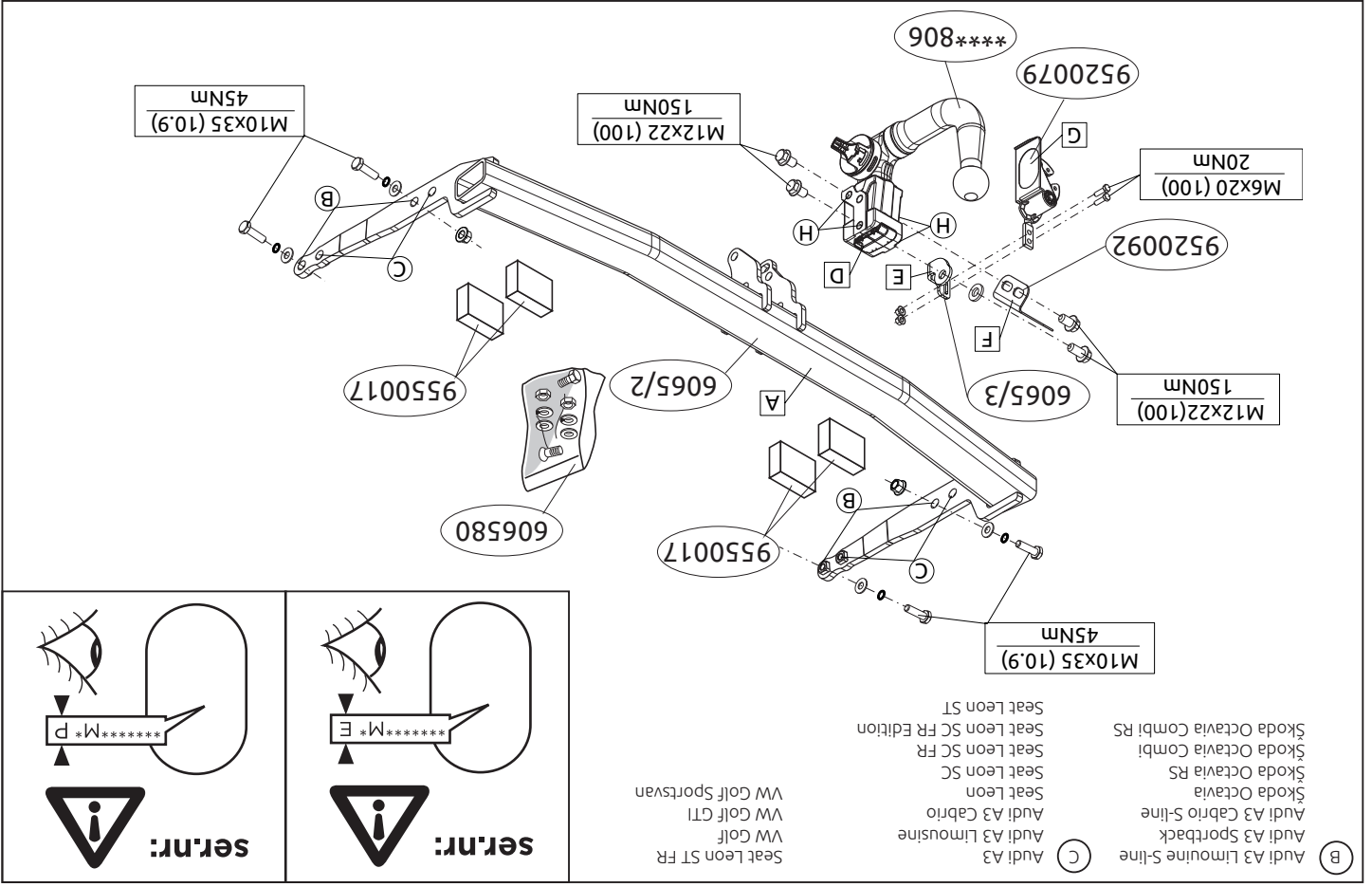

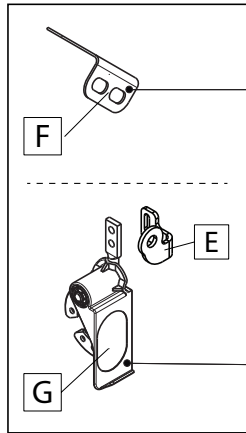

Socketplate

Foldway
socketplate

Audi A3 Sportback
Audi A3 Cabrio S-line
Audi A3
Audi A3 Limousine
Audi A3 Cabrio

G

Škoda Octavia
Škoda Octavia RS
Škoda Octavia Combi
Škoda Octavia Combi RS

G

Seat Leon
Seat Leon FR
Seat Leon SC
Seat Leon ST FR
Seat Leon SC FR Edition

F

Seat Leon ST

G

VW Golf
VW Golf GTI
VW Golf Sportsvan

G

© 606570/19-01-2024/6



F- Socketplate

Seat Leon FR
Seat Leon SC FR

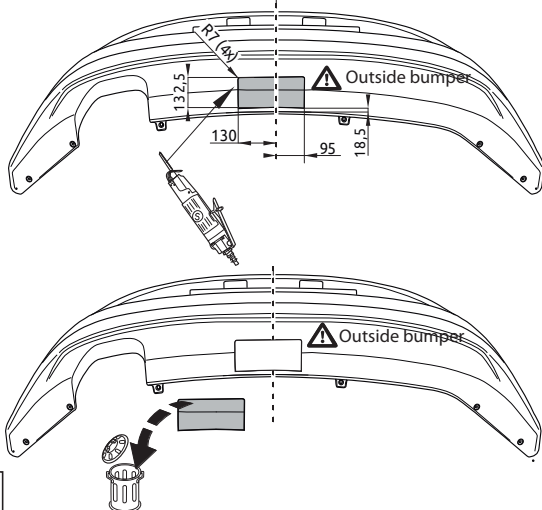
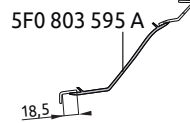
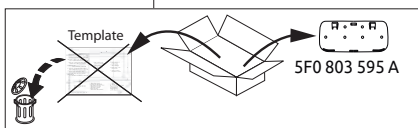
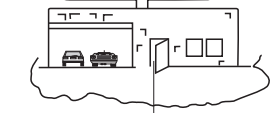

12

Seat Leon SC FR Edition

F- Foldway socketplate

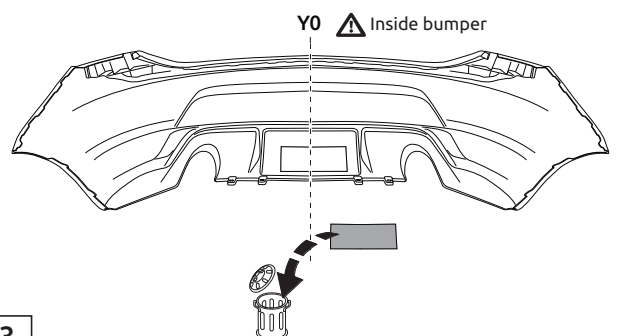
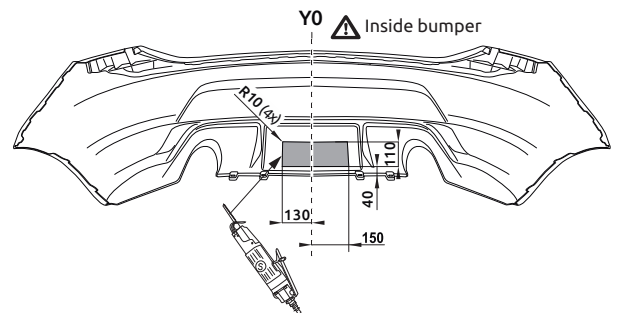
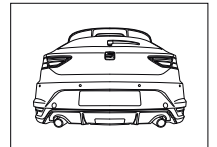

13

© 606570/19-01-2024/23

- (4x) M12x25 (100)
- (4x) M10x35 (10.9)
- (2x) M6x20 (10.9)
- (4x) M10 (4x) M10 (4x) M10 (1x) M12

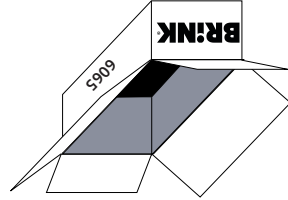
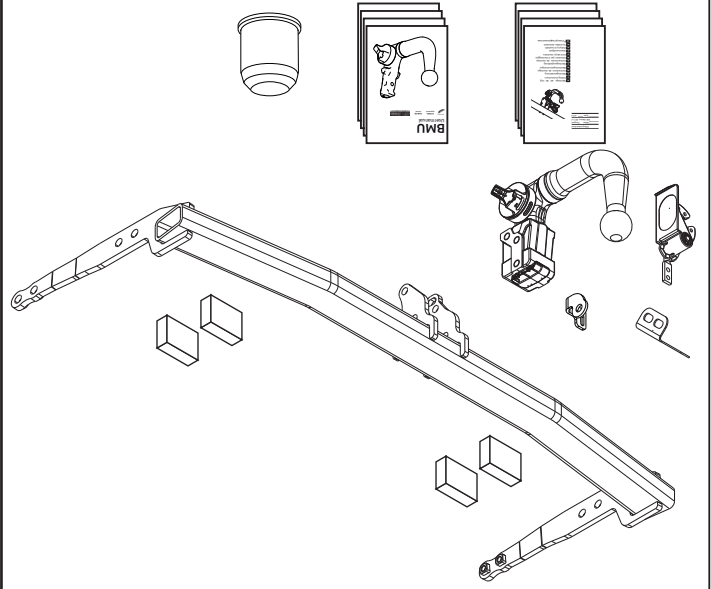
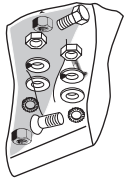
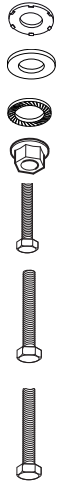

11

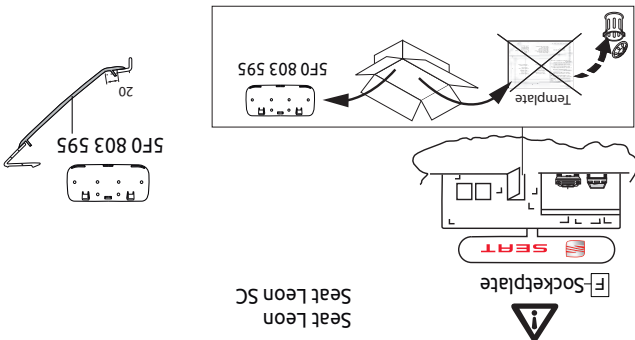
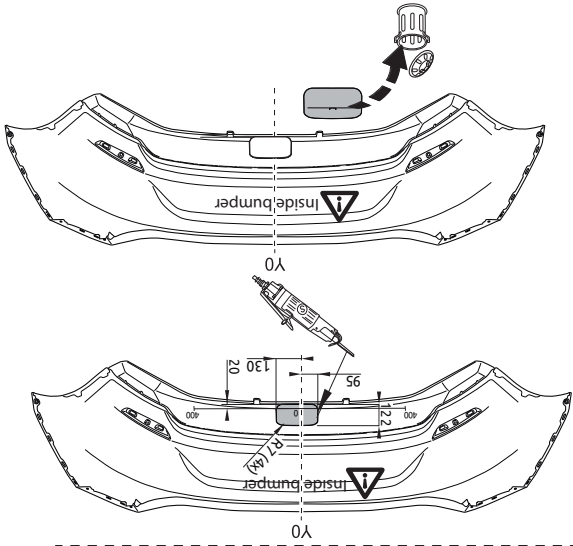

10a

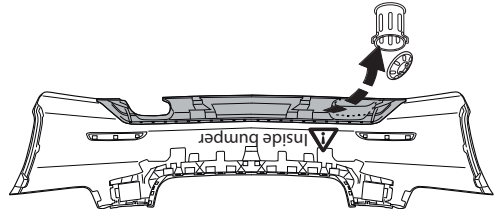
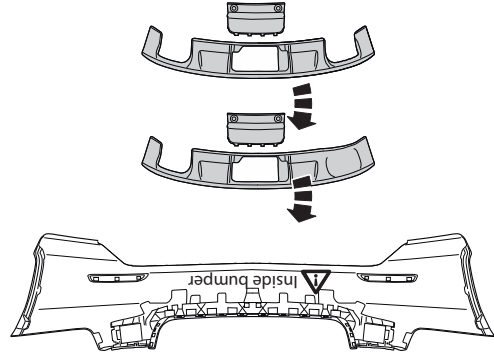

8V5.807.521.C

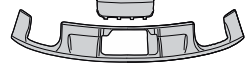

8V5.807.521.A

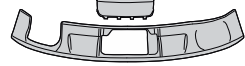

Audi A3 Cabrio

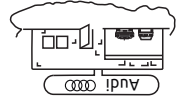

Foldway socketplate



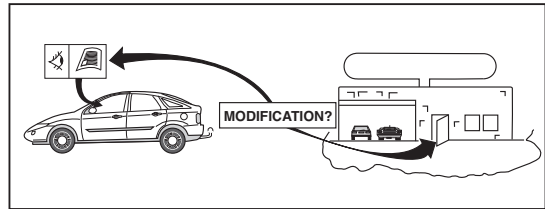
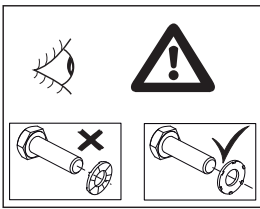
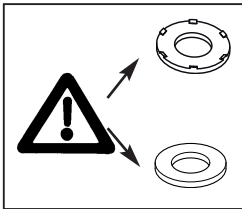
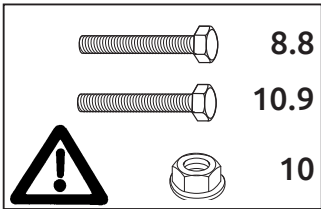
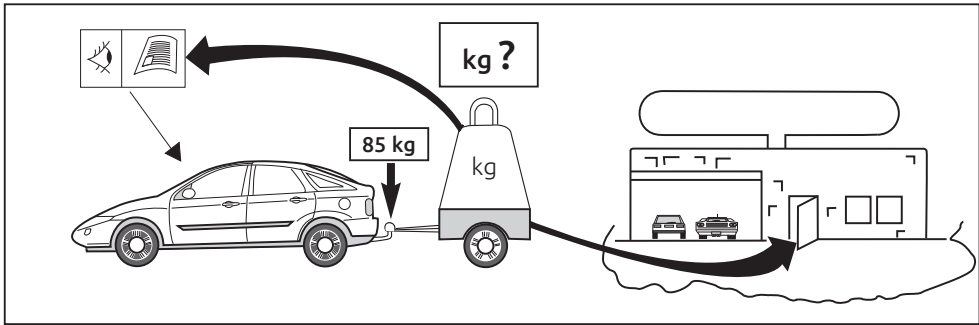
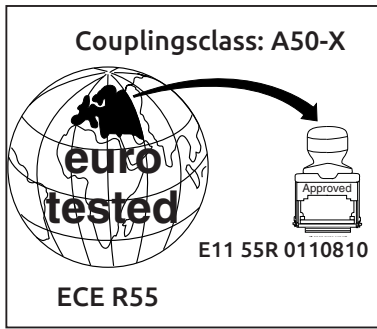
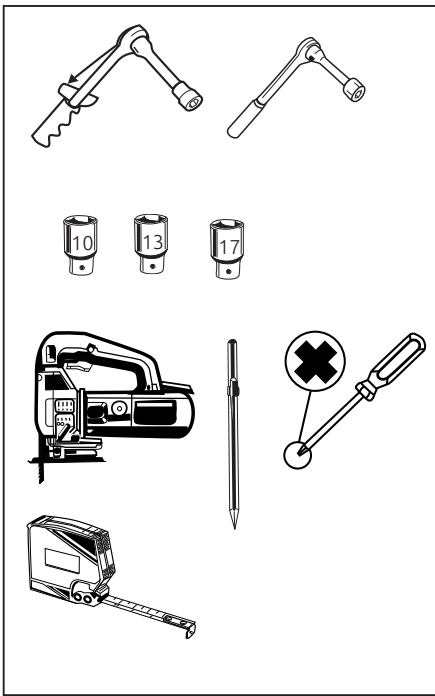

© 606570/19-01-2024/8

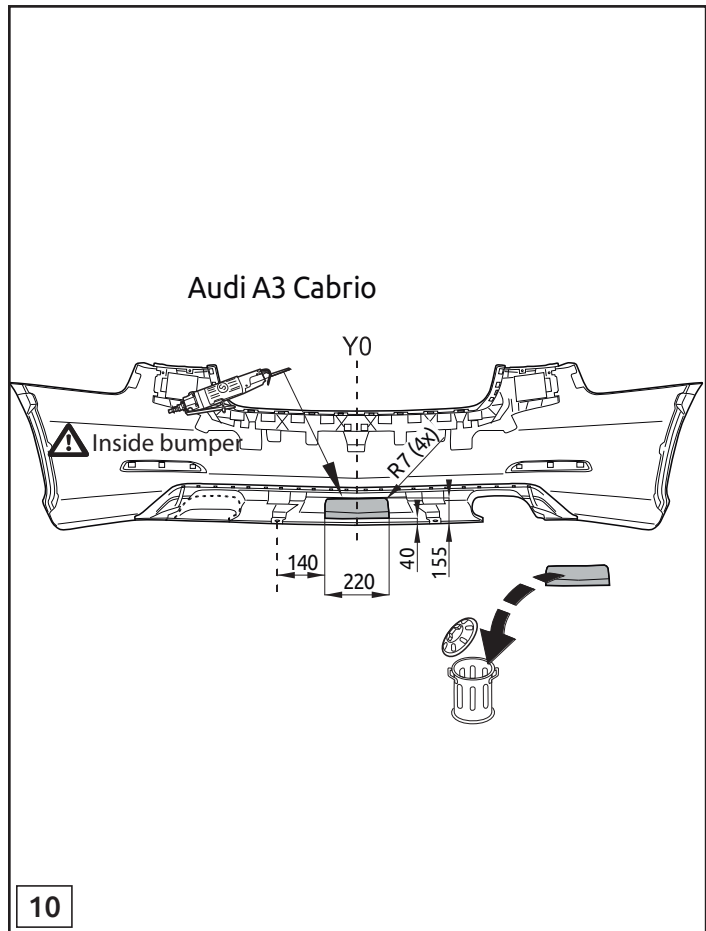
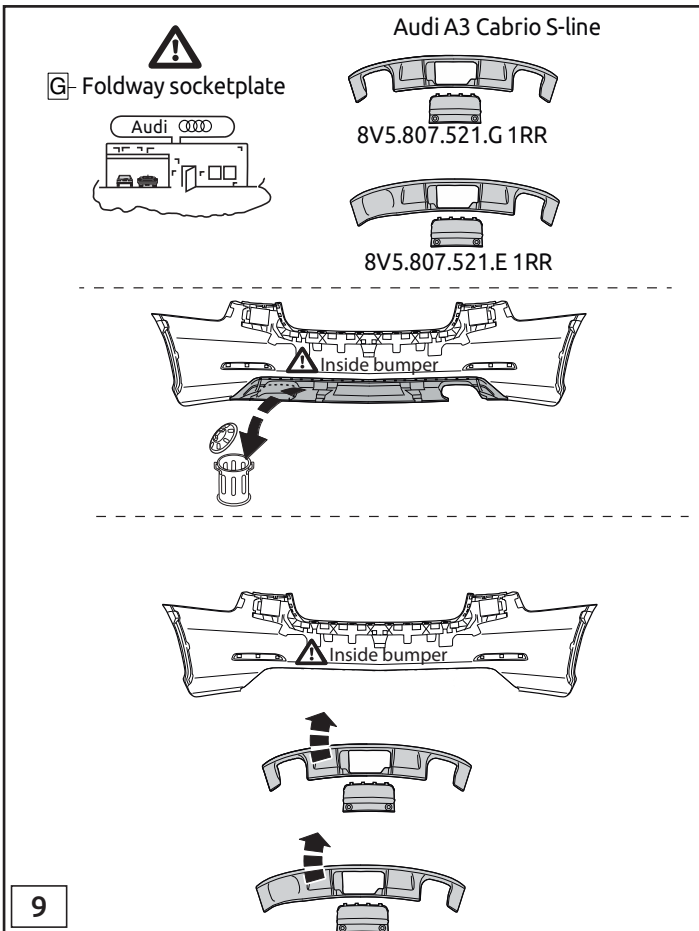

© 606570/19-01-2024/21

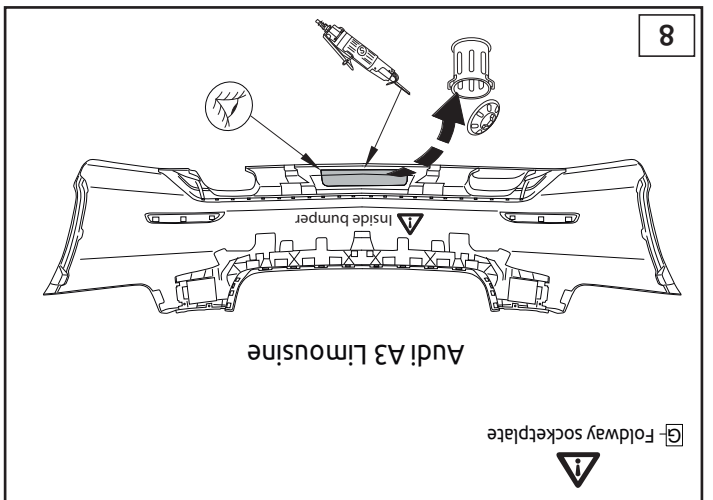
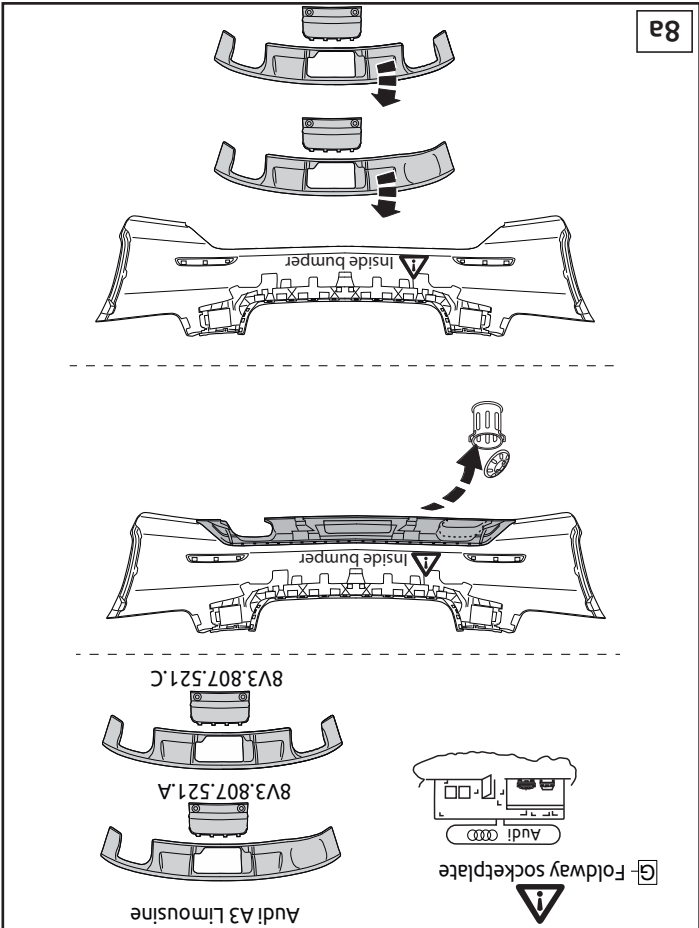
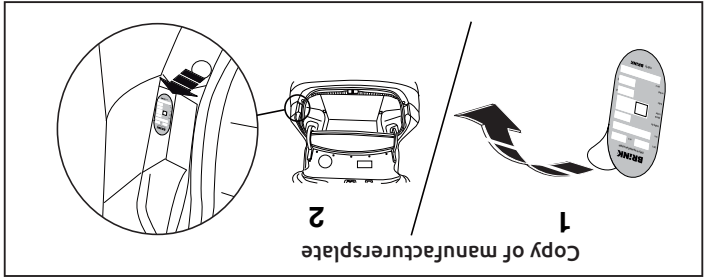
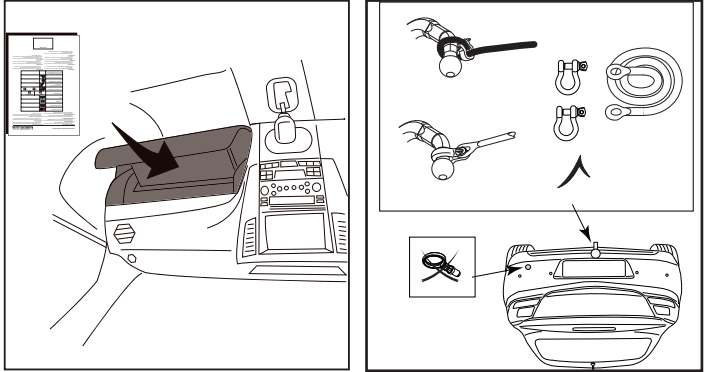
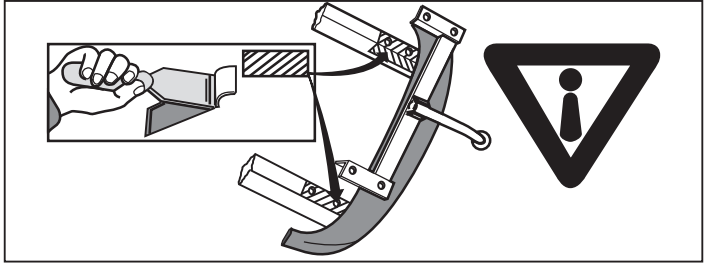
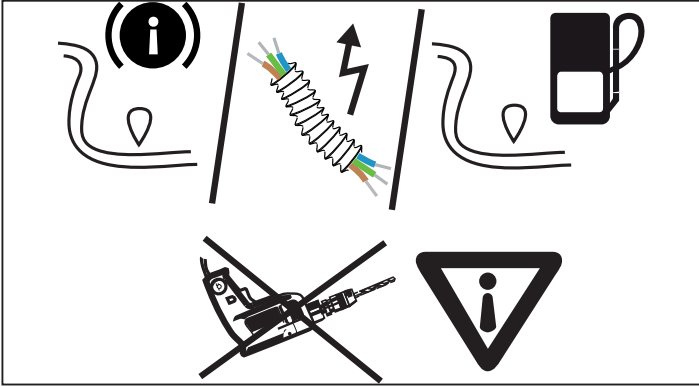
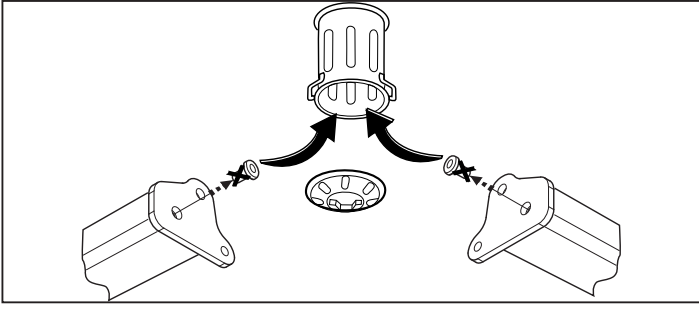

NL

* Brink Towing Systems B.V. is niet aansprakelijk voor de schade die het direct of indirect gevolg is van onjuiste montage, daaronder begrepen gebruik van niet-geschikte gereedschappen en het gebruik van andere dan de voorgeschreven montagewijze en middelen, dan wel onjuiste interpretatie van dit onderhavig montagevoorschrift.

GB

NOTE:

* **Should this installation process entail the cutting of the bumper – conformation MUST be obtained by the installation engineer of the customer's acceptance prior to completion. Brink Towing Systems B.V. do not accept responsibility for any matters arising as a result of this miscommunication.**

All measurements are in mm!

* Brink Towing Systems B.V. is not liable for damage caused directly or indirectly by incorrect assembly, including the use of unsuitable tools, the use of other assembly methods and means than the ones outlined, and the incorrect interpretation of these assembly instructions.

D

HINWEISE:

* Die für das Fahrzeug zugelassene Anhängelast ist den Fahrzeug Unterlagen zu entnehmen. Bei Änderungen des Fahrzeuggewichtes muß die höchstzulässige Anhängelast gegebenenfalls aus dem D-Wert nachgerechnet werden. Auskunft hierüber kann Ihr Fachhändler oder der TÜV geben.

* Elektrische Anlage gemäß StVZO anbringen.

* Brink Towing Systems B.V. haftet nicht für Schäden, die als direkte oder indirekte Folge einer nicht ordnungsgemäßen Montage auftreten, darunter fallen auch die Benutzung von ungeeigneten Werkzeugen, andere als die vorgeschriebenen Montageverfahren und Montagemittel

sowie eine fehlerhafte Interpretation der betreffenden Montageanweisung.

F

* Brink Towing Systems B.V. décline toute responsabilité pour les dommages qui pourraient directement ou indirectement résulter d'un montage incorrect, y compris l'utilisation d'outils inappropriés et l'utilisation d'un mode d'emploi et de moyens autres que ceux prescrits, ou bien résulter d'une interprétation inexacte des présentes instructions de montage.

S

* Brink Towing Systems B.V. är inte ansvariga för skada som orsakats direkt eller indirekt av felaktig montering, inklusive användning av olämpliga verktyg, andra monteringsmetoder och processer än de som beskrivs, samt felaktig tolkning av dessa monteringsinstruktioner.

DK

* Brink Towing Systems B.V. er ikke ansvarlig for skade der direkte eller indirekte er forårsaget af forkert montage, herunder også iberegnet brug af forkert værktøj og anvendelse af anden montage metode og andre montage midler end de foreskrevne samt fejltolkning af den medfølgende montagevejledning.

E

* Brink Towing Systems B.V. no se responsabiliza por daños causados, directa o indirectamente, por un montaje incorrecto, incluyendo el uso de herramientas inadecuadas, por el uso de métodos de montaje y medios distintos a los indicados y por la interpretación incorrecta de estas instrucciones de montaje.

© 606570/19-01-2024/10

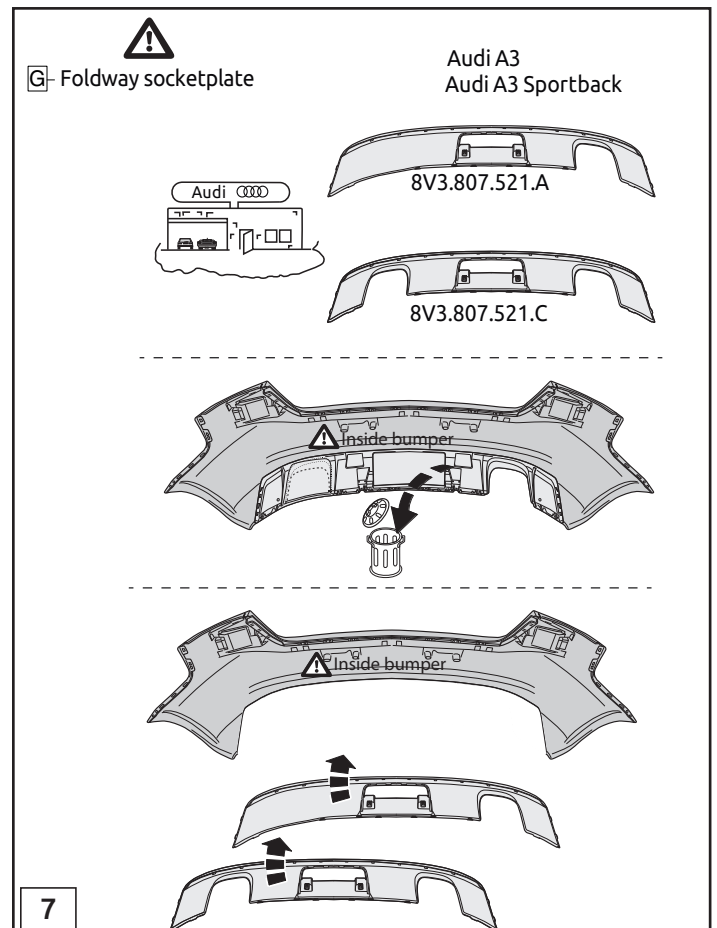
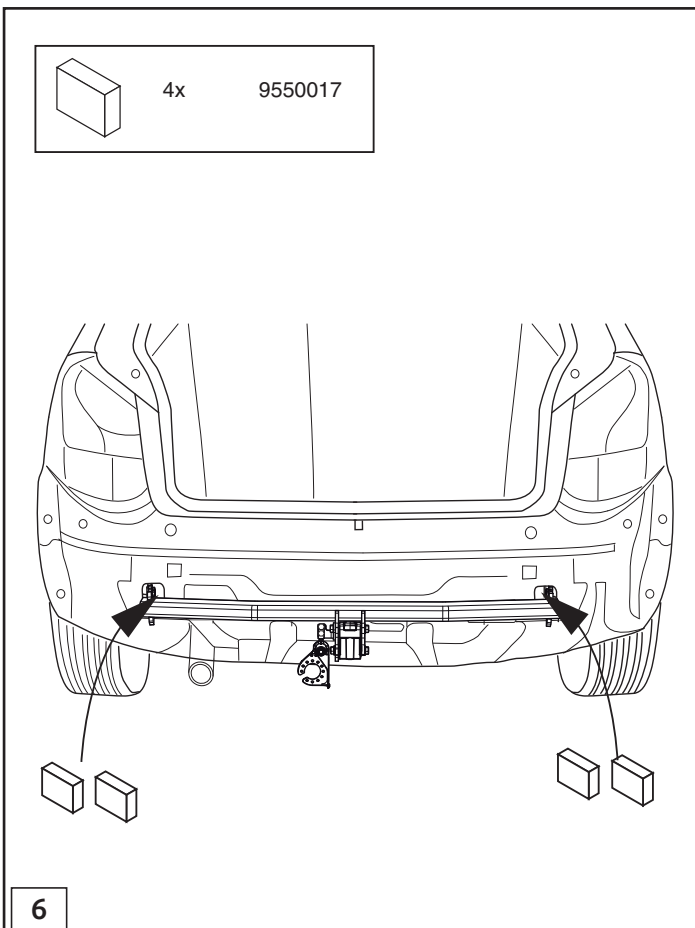

© 606570/19-01-2024/19

* A Brink Towing Systems B.V. nem vállal felelősséget a nem megfelelő szerelésből közvetlen vagy közvetett módon következő károkat. Ez vonatkozik a nem megfelelő szerzők használatára, a leírattól eltérő módszerek és eszközök alkalmazására, valamint a szerelési útmutató

H

* Společnost Brink Towing Systems B.V. neodpovídá za přímé ani nepřímé škody způsobené nesprávnou montáží, včetně použití nevhodných nástrojů, použití jiných metod montáže a prostředků než uvedených a nesprávným pochopením těchto pokynů k montáži.

CZ

* Brink Towing Systems B.V. ei ole vastuussa violtumisesta, joka on suor-
aan tai epäsuoraan aiheuttanut väärästä asennuksesta samoin kuin sopi-
matomien työkalujen käytöstä, muiden kuin ohjeissa mainittujen asen-
nustenetelmien tai välineiden käytöstä sekä kyseisten asennusohjeiden
väärintulkinnasta.

SF

* Brink Towing Systems B.V. nie ponosi odpowiedzialności za straty
poniesione pośrednio lub bezpośrednio na skutek niewłaściwego
montażu, w tym użycia niewłaściwych narzędzi i sposobów montażu
niegodnych z instrukcją, oraz niezastosowanie się do treści instrukcji.

PL

* Brink Towing Systems B.V. non può essere ritenuta responsabile per
eventuali danni direttamente o indirettamente dovuti ad un errato mon-
taggio, intendendo con ciò anche l'uso di attrezzi non idonei e l'uso di
metodi e mezzi di montaggio diversi da quelli prescritti, nonché all'errata
interpretazione delle seguenti istruzioni di montaggio.

I

téves értelmezésre.

RUS

* Фирма Brink Towing Systems B.V. не отвечает за ущерб, являющийся
прямым или косвенным следствием неправильного монтажа, в том
числе использования неподходящих инструментов и примененных
иного способа монтажа или других средств, чем предписано в
инструкции, либо неправильного истолкования настоящей инструк-
ции по монтажу.

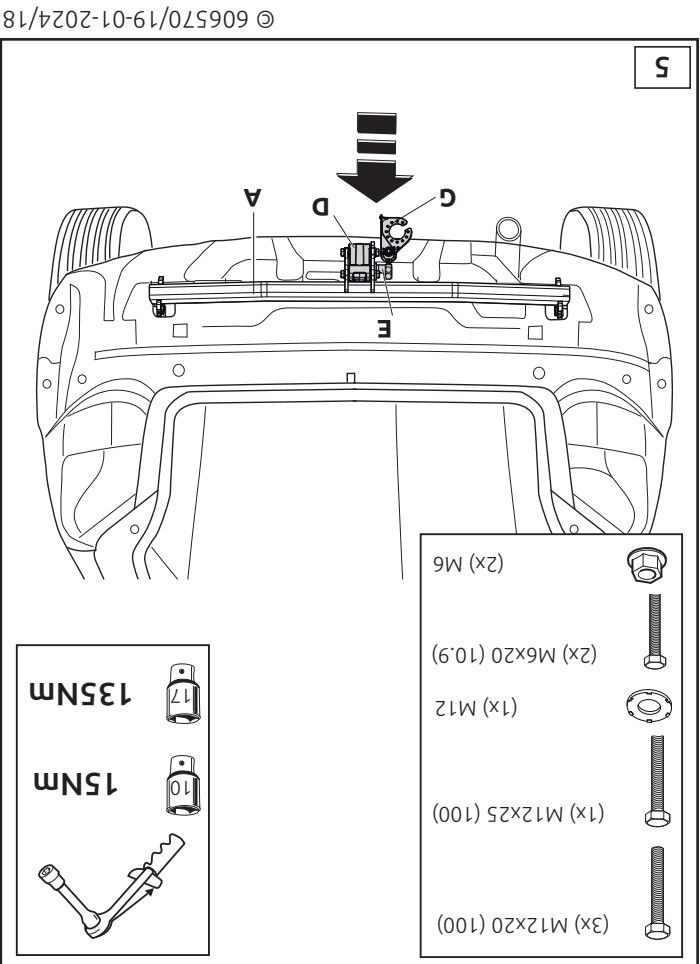
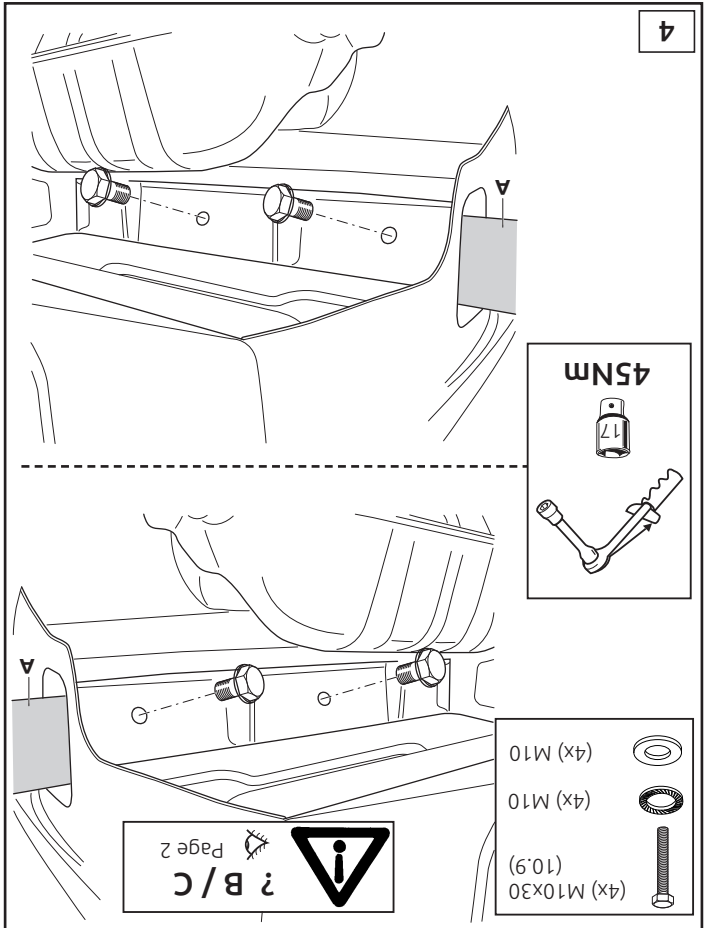

- NL** Lokatie/Positie pijl
- GB** Location/Position Arrow
- D** Positionspfeil
- F** Flèche de Position
- S** Positionpil
- DK** Lokaliseringspil
- E** Flecha de posición
- I** Freccia di posizione
- PL** Strzałka położenia
- SF** Paikannusnuoli
- CZ** Šípka na pozici
- H** Helyzetjelző nyíl
- RUS** Локация / Место

- NL** Richtingspijl
- GB** Movement Arrow
- D** Bewegungspfeil
- F** Flèche de mouvement
- S** Rörelsepil
- DK** Bevægelsespil
- E** Flecha de movimiento
- I** Freccia di movimento
- PL** Strzałka kierunku ruchu
- SF** Liikesuuntanuoli
- CZ** Šípka pohybu
- H** Mozgásirányjelzőnyíl
- RUS** Стрелка движения

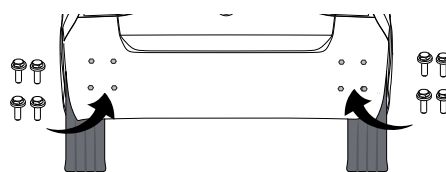
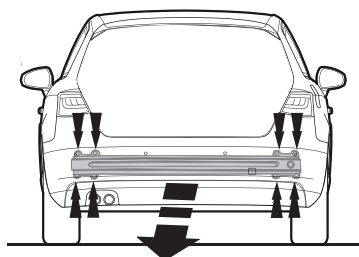
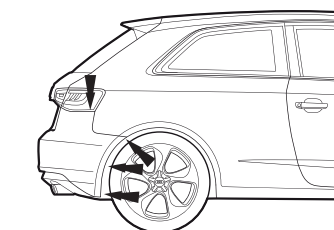
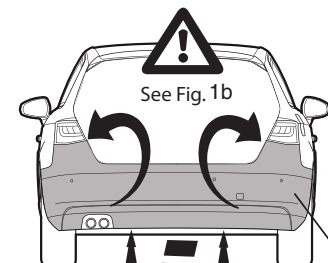
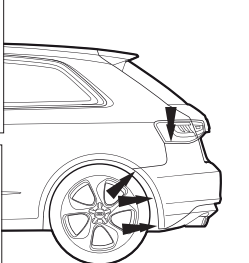
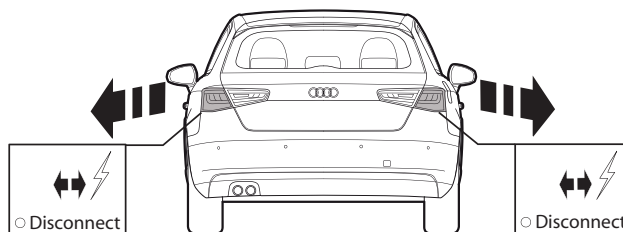

1a

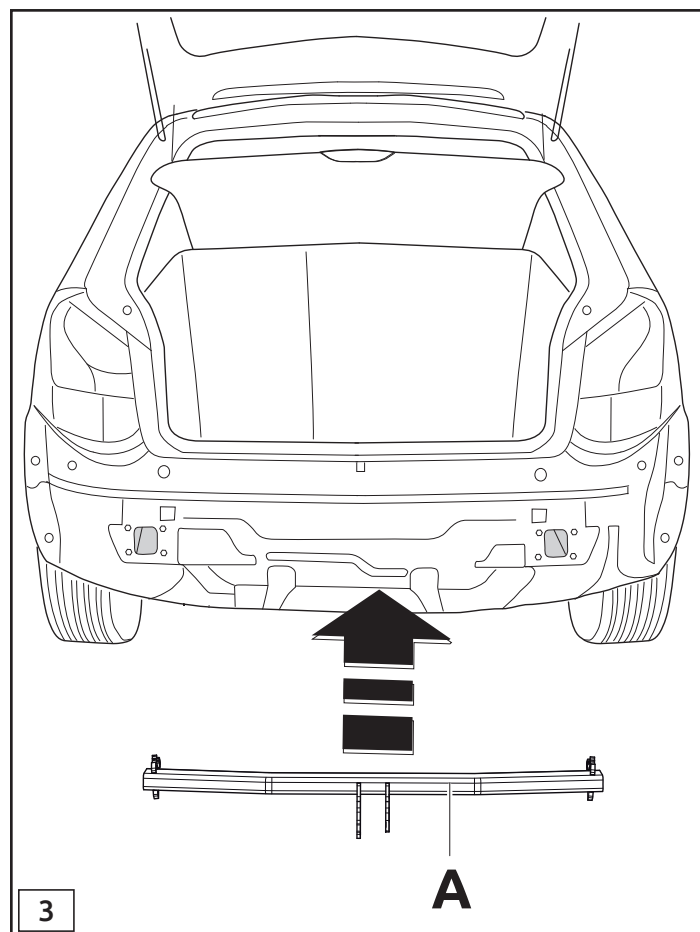
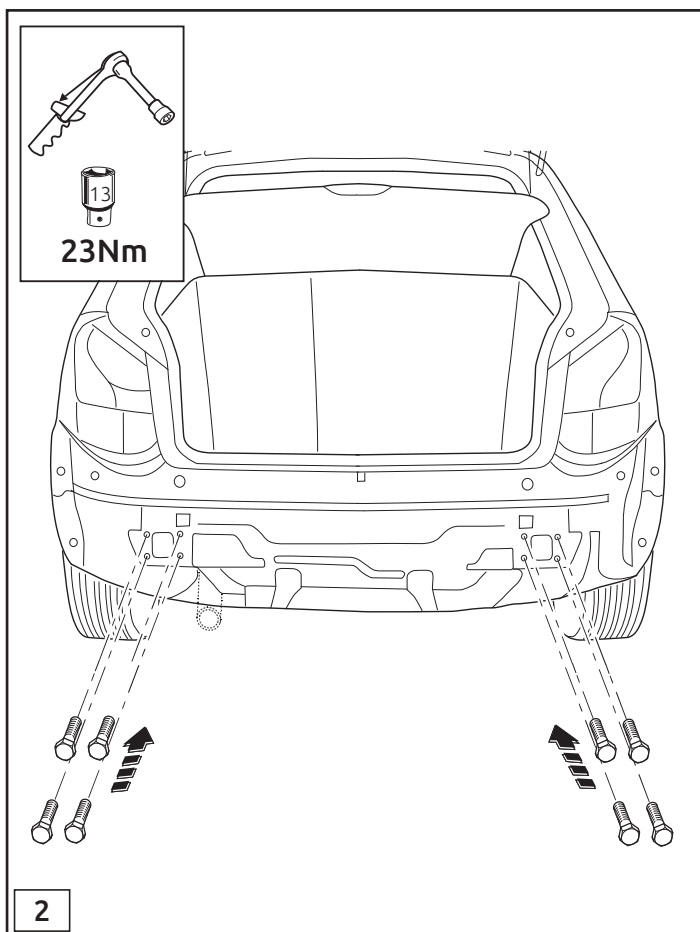

2

3

Inside trunk / back panel

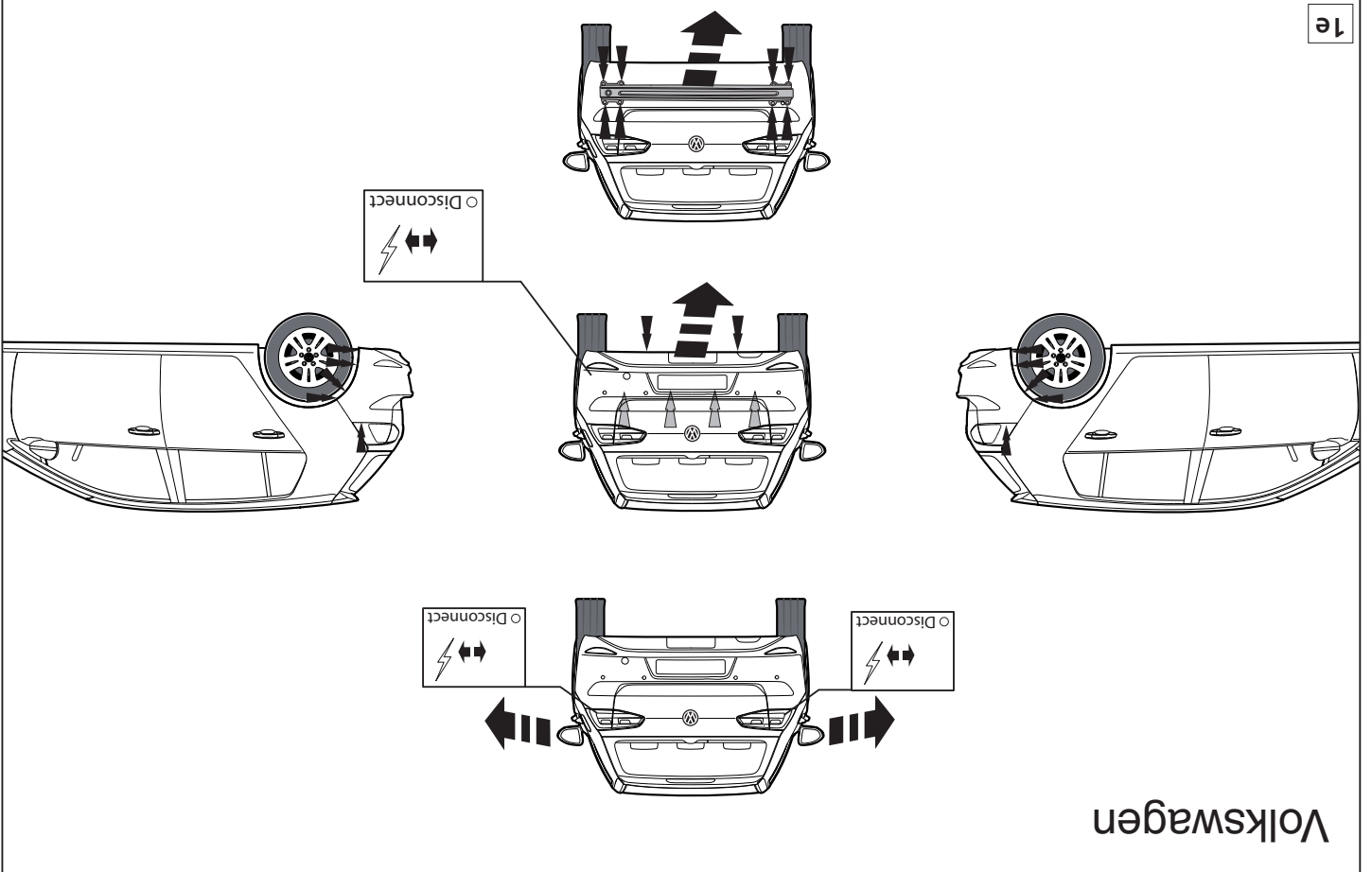
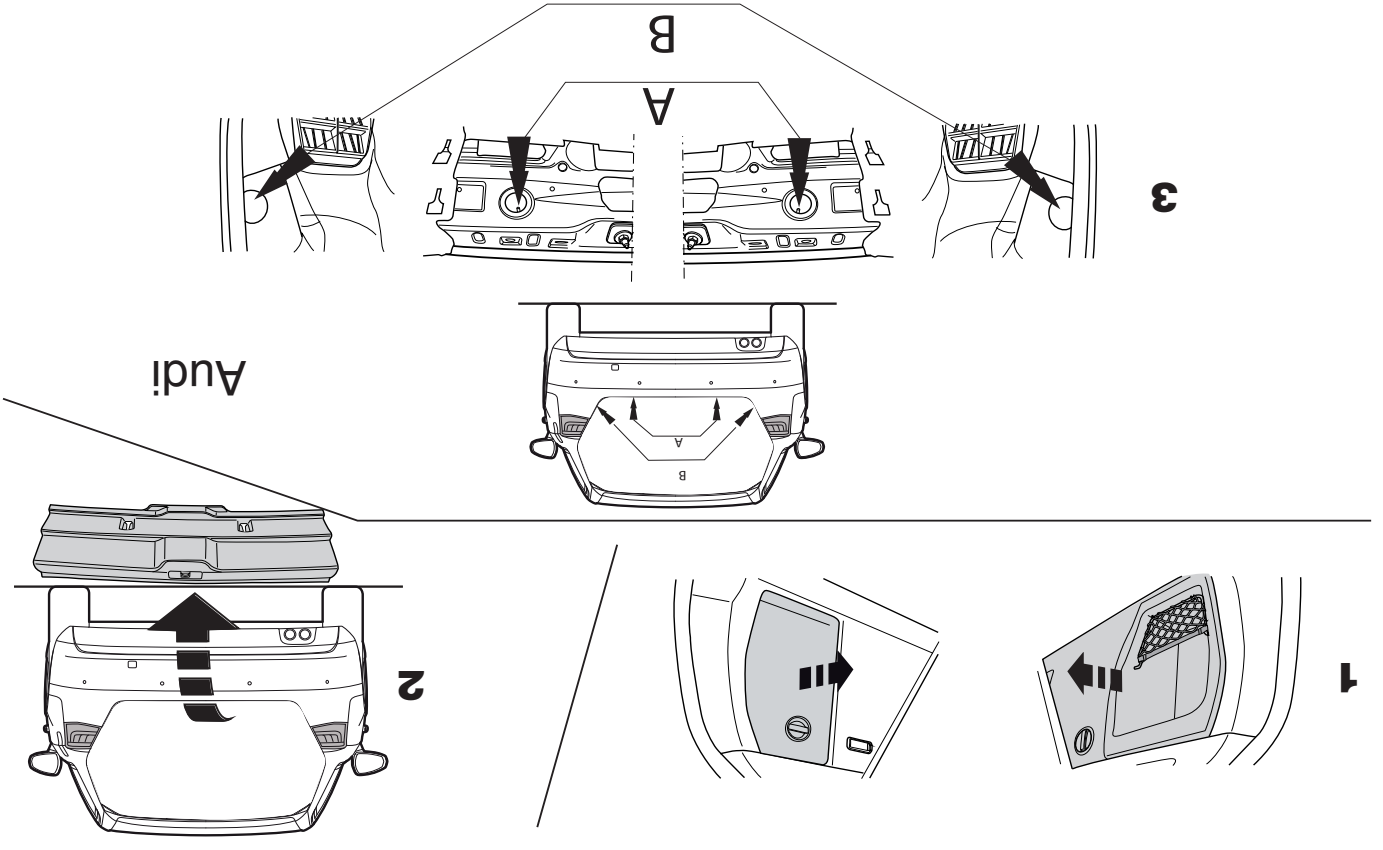

Skoda

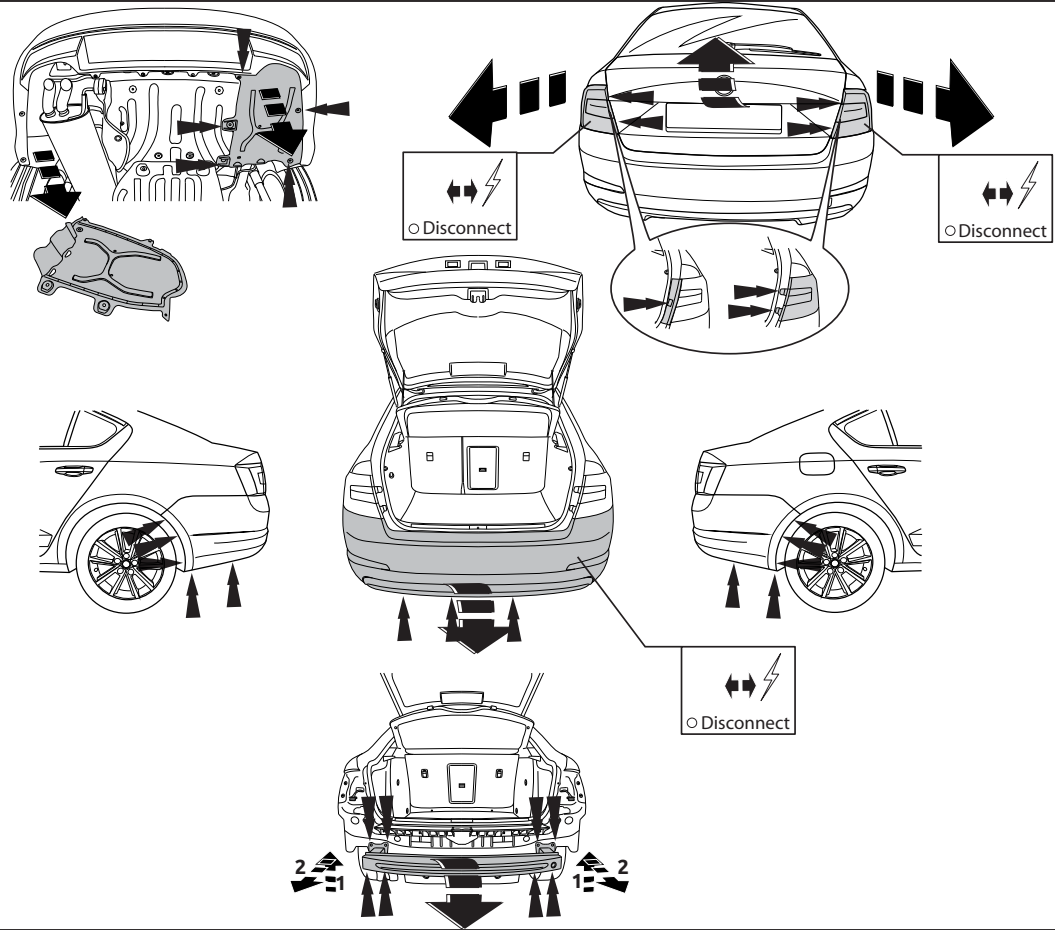

1c

© 606570/19-01-2024/14

Seat

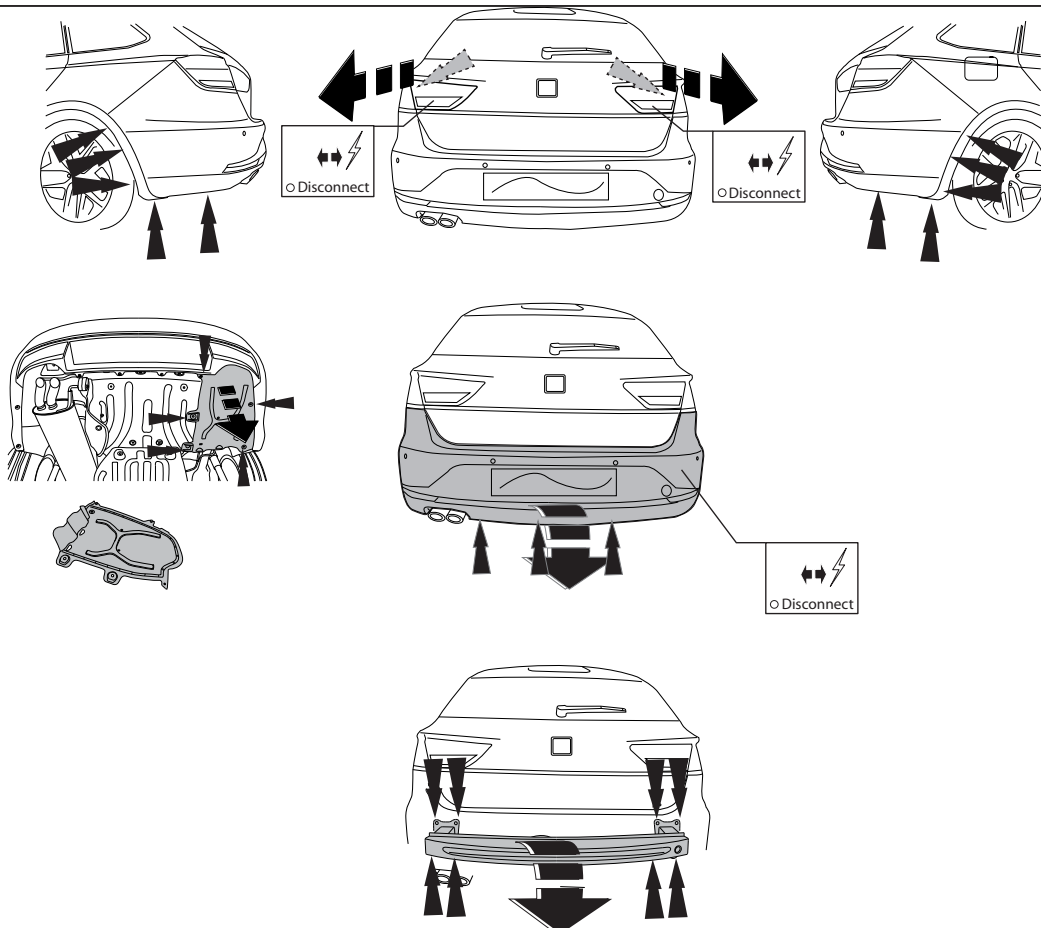

1d

© 606570/19-01-2024/15



Smart positioning sticker 6065

Place on outside bumper



Skoda Octavia HB/Combi; 2020-> without existing hole

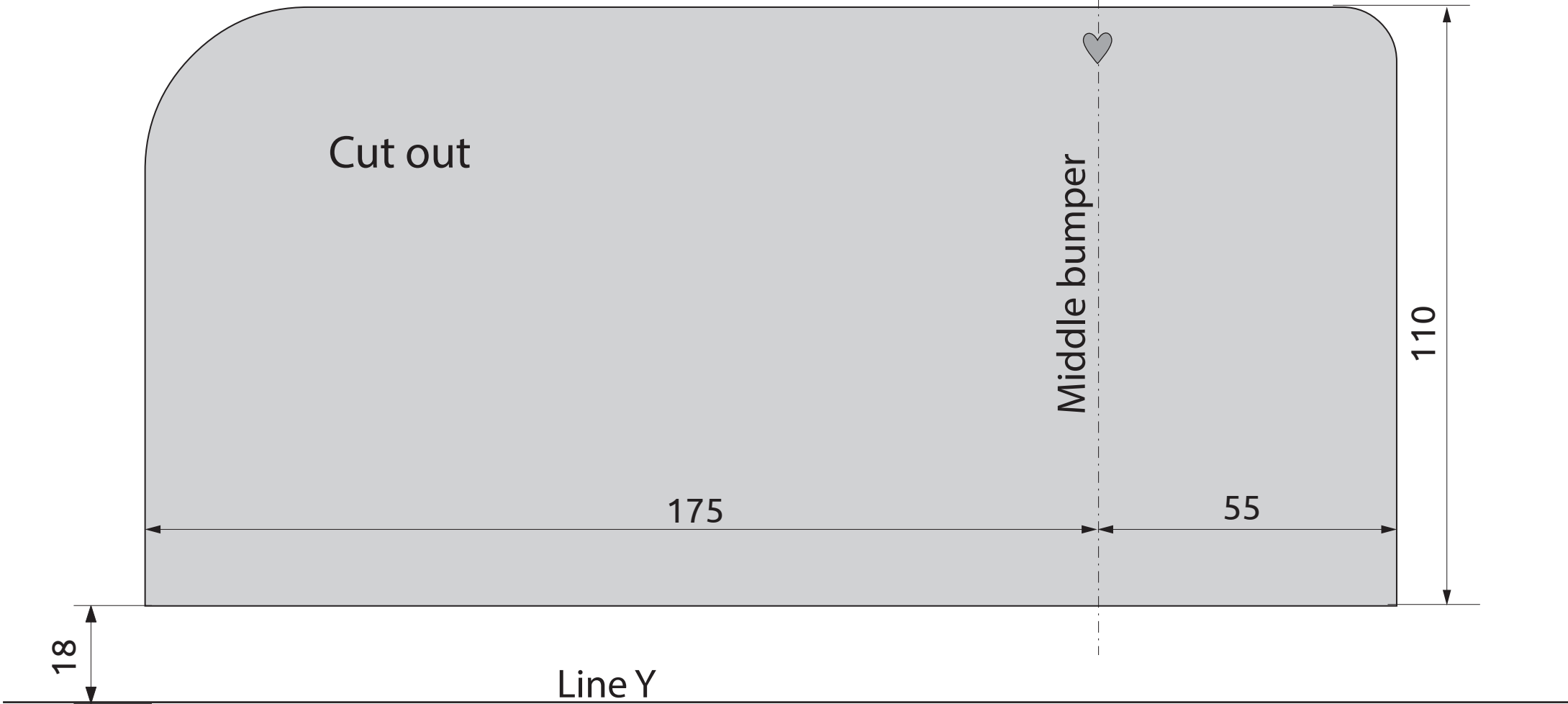
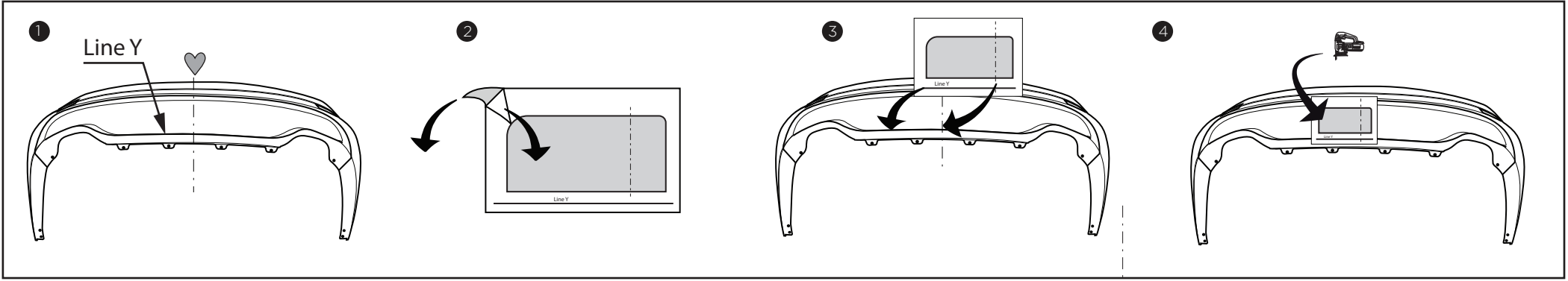



Smart positioning sticker 6065

Place on outside bumper

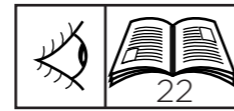

Skoda Octavia HB/Combi; 2020->

With existing hole

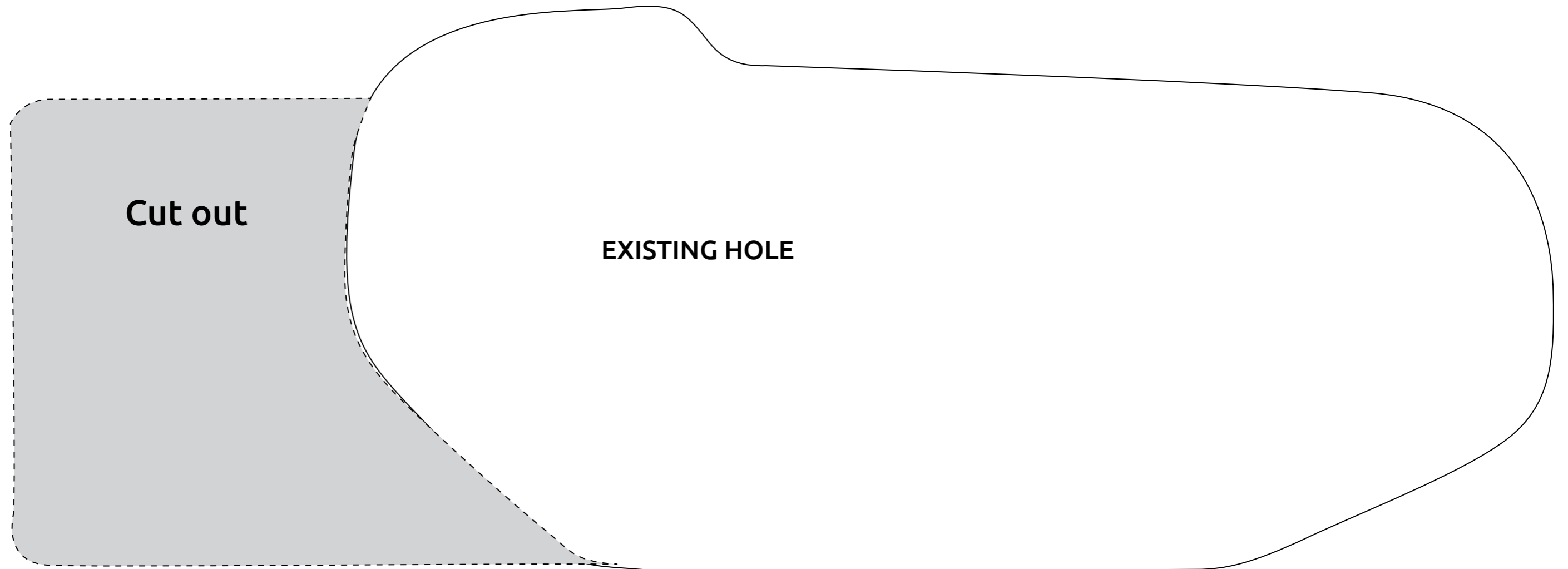
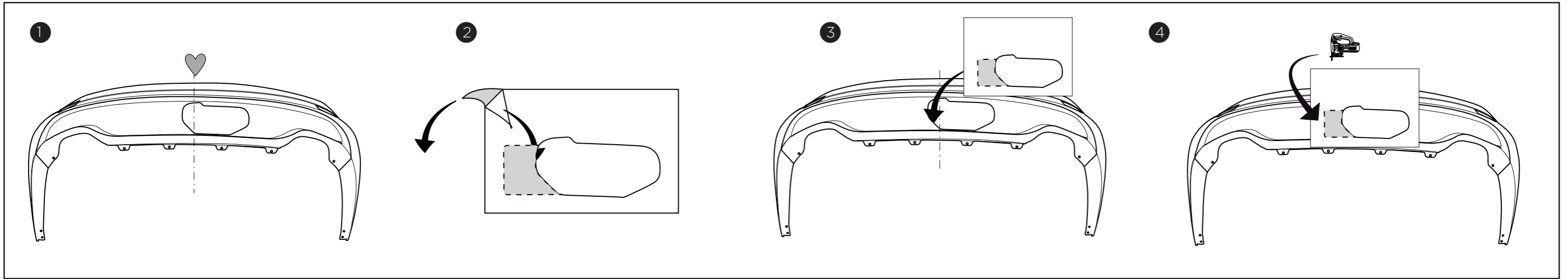

BEND LINE