

Installation Manual

C-2614
ARNOTT COIL SPRING CONVERSION KIT
1990-2002 LINCOLN TOWN CAR
**1990-2002 FORD CROWN VICTORIA/
MERCURY GRAND MARQUIS**

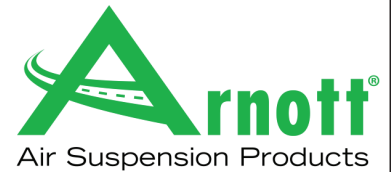

Congratulations on your purchase of an Arnett® air suspension product. We at Arnett Incorporated are proud to offer a high quality product at the industry's most competitive pricing. Thank you for your confidence in us and our product.

Proper installation is essential to experience and appreciate the benefits of this system. Please take a moment to review these installation instructions before you begin to install these components on your vehicle. The removal and installation of air suspension products should only be performed by a fully qualified, ASE Certified, professional.

It is equally important to be aware of all necessary safety measures while installing your new Air Suspension System. This includes proper lifting and immobilizing of the vehicle and isolation of any stored energy to prevent personal injury or property damage.

"Engineered to Ride, Built to Last®"



WARNING: *The air suspension system is under pressure (up to 10 bar, or 150 lbf/in). Verify pressure has been relieved and disconnect power to the air suspension system prior to disassembly. Do not allow dirt or grease to enter the system. Always wear standard hand, ear, and eye protection when servicing the air suspension system.*

Arnett® is committed to the quality of its products. If you have a question or problem with any Arnett product, please contact Arnett by calling **800-251-8993** during normal business hours or email techassistance@arnottinc.com. (In the EU please call +31 (0)73 7850 580 or email info@arnotteurope.com).

GENERAL INFORMATION:

Reading this manual signifies your agreement to the terms of the general release, waiver of liability, and hold harmless agreement, the full text of which is available at www.arnottinc.com.

- Not to be stored below 5°F (-15°C) or above 122°F (50°C).
- Avoid damage to air lines and cables.
- Removal and installation is only to be performed by fully qualified personnel.
- Use car manufacturer's diagnostic software.

CAUTION: Damage to the vehicle and air suspension system can be incurred if work is carried out in a manner other than specified in the instructions or in a different sequence.



To avoid the possibility of short circuits while working with electric components consult your owner's manual on how to disconnect your battery.



Consult your vehicle owner's manual, service manual, or car dealer for the correct jacking points on your vehicle and for additional care, safety and maintenance instructions. Under no circumstances should any work be completed underneath the vehicle if it is not adequately supported, as serious injuries and death can occur.

AIR SPRING REMOVAL

1. TURN AIR SUSPENSION SWITCH TO THE **OFF** POSITION (SWITCH IS LOCATED ON THE LEFT SIDE OF THE TRUNK). (FIGURE 10-1)



FIGURE 10-1

2. SET THE STEERING TO STRAIGHT AHEAD.
3. RAISE THE VEHICLE.
4. REMOVE THE REAR WHEELS.

5. REMOVE AIR SPRING SOLENOID RETAINING CLIP. (FIGURE 10-2)
6. REMOVE ELECTRICAL CONNECTOR AND AIR LINE FROM AIR SPRING SOLENOID VALVE. (FIGURE 10-2)
7. ROTATE SOLENOID COUNTER-CLOCKWISE TO THE FIRST STOP, AND THEN CAREFULLY PULL OUT TO VENT THE AIR PRESSURE FROM THE AIR SPRING. AFTER AIR SPRING IS DEFLATED, TURN AGAIN AND COMPLETELY REMOVE SOLENOID FROM AIR SPRING. (FIGURE 10-2)

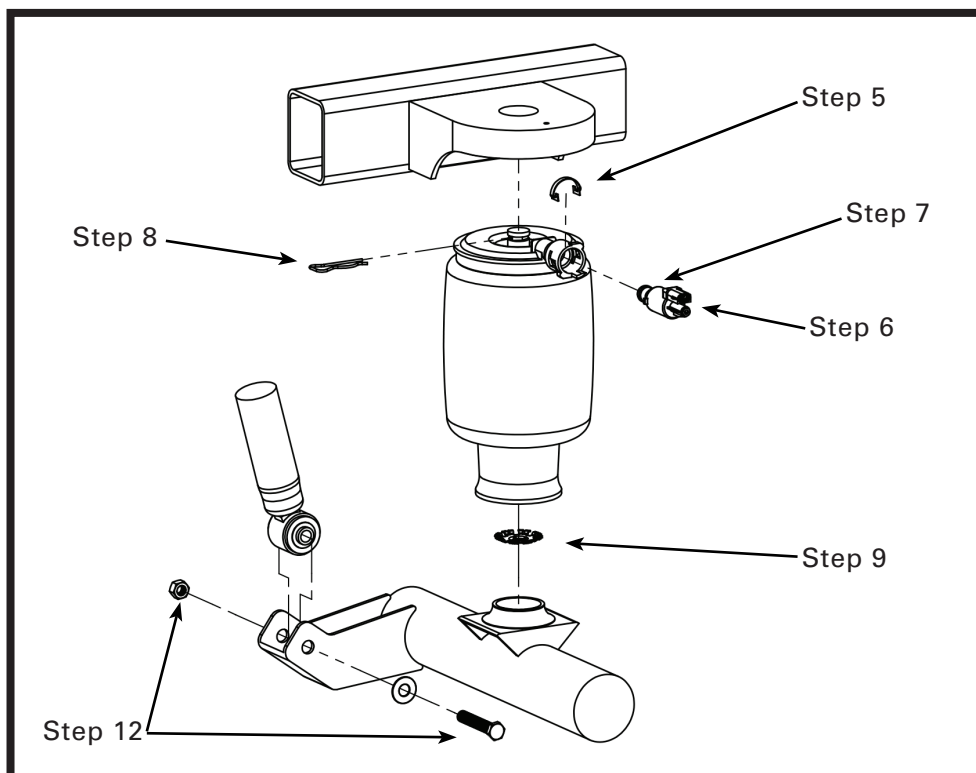

FIGURE 10-2

8. WITH PLIERS, OR A SUITABLE HOOKED TOOL, REMOVE THE CLIP THAT SECURES THE TOP OF THE AIR SPRING TO THE CHASSIS. **NOTE: TO ACCESS THE CLIP, GO UNDER THE WHEEL ARCH, BETWEEN THE BODY OF THE VEHICLE AND THE CHASSIS.** (FIGURE 10-3)



FIGURE 10-3

9. REMOVE THE PISTON-TO-AXLE SPRING SEAT CLIP. (AIR SPRING IS HELD IN PLACE WITH A ROUND RETAINER CLIP UNDER THE PISTON CAP. TO UNSNAP CLIP, GENTLY PRY BETWEEN THE PISTON AND THE AXLE. CLIP WILL UNSNAP WHEN PRESSURE IS APPLIED). (FIGURE 10-4)

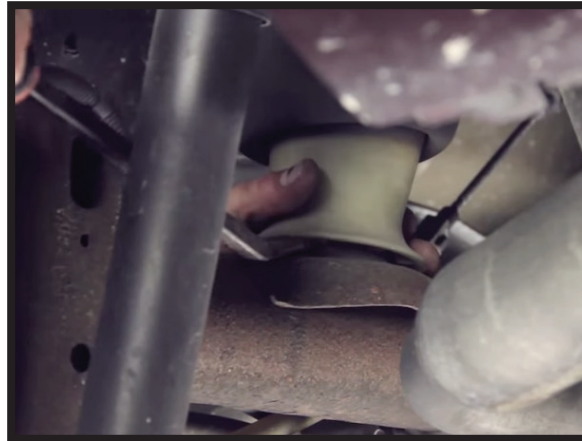

FIGURE 10-4

10. CAREFULLY REMOVE AIR SPRING FROM THE VEHICLE.
11. SEAL OFF HOSE TO PREVENT DIRT OR GREASE FROM ENTERING SYSTEM.
12. REMOVE BOTH UPPER AND LOWER SHOCK BOLTS. ALLOW AXLE TO HANG FREE UNSUPPORTED. THIS WILL GIVE YOU EXTRA CLEARANCE FOR THE COIL SPRING. (FIGURE 10-5)

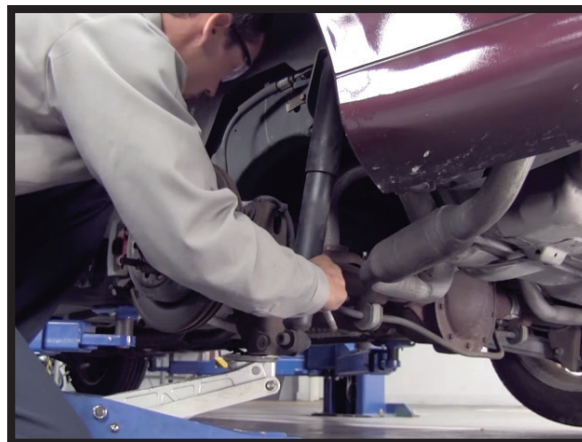

FIGURE 10-5

13. REMOVAL COMPLETE.

COIL SPRING INSTALLATION



Tighten all nuts and bolts to manufacturer's specifications during the installation process.

1. INSTALL THE COIL SPRINGS ONTO THE REAR AXLE. (FIGURE 20-1)



FIGURE 20-1

2. USING A FLOOR JACK, RAISE THE REAR AXLE. (FIGURE 20-2)



FIGURE 20-2

3. INSTALL THE NEW SHOCK ABSORBER'S RETAINING NUTS AND BOLTS TO THE REAR AXLE, TIGHTENING TO MANUFACTURE'S SPECIFICATION. (FIGURE 20-3)

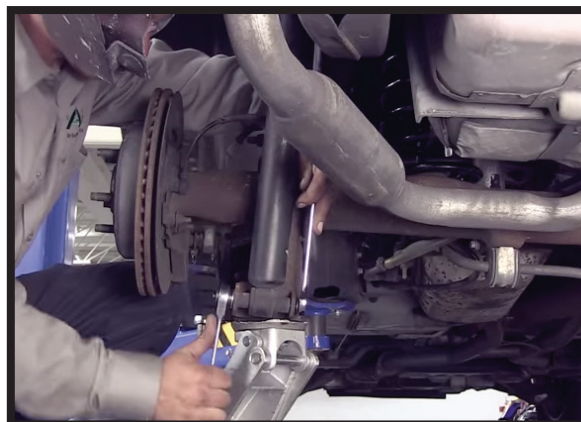

FIGURE 20-3

DISARMING VEHICLE'S AIR SUSPENSION

1990-1994

THE MODULE IS LOCATED IN THE TRUNK, BEHIND THE AIR SUSPENSION SWITCH. PULL BACK THE TRUNK CARPET AND REMOVE THE 2 NUTS THAT MOUNT THE AIR SUSPENSION MODULE. UNPLUG THE AIR SUSPENSION MODULE AND BOLT IT BACK IN PLACE.

1995-1997

THE MODULE IS LOCATED BEHIND THE GLOVE BOX. FLIP THE GLOVE BOX DOWN AND LOCATE THE AIR SUSPENSION MODULE MOUNTED ON THE HEATER CORE DIRECTLY IN FRONT OF YOU. UNPLUG THE MODULE AND CLOSE GLOVE BOX.